

User Manual for advanced axial flux synchronous motors and generators



Contents

1. Technical data of EMRAX motors.....	6
EMRAX 188 Technical Data Table.....	11
EMRAX 208 Technical Data Table (dynamometer test data).....	12
EMRAX 228 Technical Data Table (dynamometer test data).....	14
EMRAX 268 Technical Data Table (dynamometer test data).....	16
EMRAX 348 Technical Data Table.....	19
2. Intended usage of EMRAX motor/generator.....	20
3. Motor types and additional motor parts.....	20
4. Order codes, tariff (HTS) codes, weights of EMRAX motors and additional motor parts.....	23
5. 3D drawings of EMRAX motors.....	25
6. Mounting the motor.....	25
7. Power/torque transmission and shafts.....	26
8. Controlling direction, position and rotation speed of EMRAX motors.....	29
9. Suitable controllers for EMRAX motors.....	33
10. Two same sized EMRAX motors connected serially (EMRAX TWIN) – stacking capability of EMRAX motors.....	35
11. Redundancy.....	37
12. EMRAX motor working as a generator and its integration into hybrid system.....	37
13. EMRAX motor ingress protection (IP CODE).....	37
14. Motor cooling.....	38
15. EMRAX motor materials, quality and reliability.....	40
16. EMRAX motor bearings and life expectancy.....	40
17. EMRAX motors as in-wheel motors.....	41
18. Maintenance and protection of EMRAX motor against environmental disturbances.....	41
19. Starting EMRAX motor (connecting the motor with controller):.....	42
20. How to choose the correct EMRAX motor type for every application:.....	44
21. Usage of EMRAX motors for electric vehicles (EV).....	45
How to calculate power and torque for EV?.....	45
Mounting options of EMRAX motor for electric car:.....	46
Example of calculation for electric Audi ETT:.....	47
22. EMRAX Certificates.....	48
23. EMRAX disclaimer.....	48
24. Service.....	48

Table of Figures

Figure 1: EMRAX testing in Letrika d.d. company.....	5
Figure 2: EMRAX 188 side view	6
Figure 3: EMRAX 228 side view	7
Figure 4: EMRAX 228 front, back, side view	7
Figure 5: EMRAX 268 side view	8
Figure 6: EMRAX 268 VHML front, back, side view	9
Figure 7: EMRAX 348 front, back, side view	9
Figure 8: Mounting holed on front and back side of the motor	25
Figure 9: Mounting options (air propeller / in-wheel).....	25
Figure 10: Standard motor shaft.....	26
Figure 11: ESO and FSI.....	26
Figure 12: Power/torque transmission from front and/or back motor side	27
Figure 13: Power/torque transmission from front motor side to the transmission gear	27
Figure 14: Power/torque transmission from front (FSI) and/or back motor side (ESO)	28
Figure 15: Motor with extended shaft from back motor side.....	28
Figure 16: Resolver / encoder on back motor side	29
Figure 17: Resolver / encoder on the front motor side	30
Figure 18: Encoder with bracket.....	30
Figure 19: Resolver with bracket	31
Figure 20: EMRAX with hall sensors.....	31
Figure 21: Motor phase connectors – normal (UVW) and doubled (2xUVW)	32
Figure 22: EMRAX TWIN drawing	35
Figure 23: EMRAX TWIN picture	36
Figure 24: EMRAX TWIN shafts – ESO is mounted in the first motor and FSI on the front side of the second motor	36
Figure 25: Motor with extended shaft and flanged shaft on the extended shaft (for EMRAX TWIN).....	36
Figure 26: EMRAX IP65	37
Figure 27: Motor cooling options	38
Figure 28: Straight connection of motor phase connectors to controller cables.	42
Figure 29: Angular connection of motor connectors to controller cables. Connections must be isolated with shrink hose!	43
Figure 30: Isolation of electrical phase connectors with shrink hose	43

Dear customer,

Congratulations on your purchase of EMRAX electric motor.

This drive is a Slovenian product of a completely new type of pancake axial flux synchronous permanent magnet electric motor, which will keep its capability for a long time if treated the right way. It can also work as a generator with the same performance characteristics. The drive was developed for airplanes, where reliability is extremely important. Therefore our target was to build reliable, low weight, high power direct drive electric motor with high efficiency.

The drive was developed and tested by Roman Sušnik, dipl. ing. (company EMRAX d.o.o.). The first prototype was mounted on glider airplane Apis EA2 in 2008, when also the 1st electric flight in Slovenia and the 3rd on the world was made. Motor was also laboratory tested in Piktronik d.o.o (January 2011), Siemens GmbH (May 2012) and Letrika d.d. (November 2014). Furthermore our customers give us test results from their projects which are confirming our test data. In February 2014 thermal tests were performed on EMRAX motors. Motor was exposed shock tests from -40°C to +160°C for 17 days (24h/day), this means 408 hours non-stop. EMRAX passed this examination with excellent results, without any damages.

Meaning of EMRAX name:

- EM means an Electric Motor,
- R is the first letter of innovator name, who is Roman
- AX means axial magnetic flux

EMRAX motor features:

- Axial Flux
- Permanent magnet synchronous motor
- Input type: sinusoidal three phase
- Lightweight - best in class power density (up to 9kW/kg)
- High torque at low RPM
- Highly efficient (up to 98% at x kW and x RPM)
- Reliable (developed and produced for airplane industry)
- Compact and high-quality product
- IP21 or IP65
- EMC Compliant – E marked (complies with essential protection requirements of 89/336/EEC)
- Low cost
- 3 Cooling options (Air/Liquid/Combined)
- Low noise
- No vibrations
- Stacking capability (two same size motors connected on the same shaft)

EMRAX engine can achieve high power even at relatively low rotation speeds due to high torque. It allows a gearless drive without the usual step-down gear unit which causes power losses, additional weight, complexity and maintenances. In case lower output rotation is needed reduction drive can be used, which allows even higher torque (power stays the same).

EMRAX motor ranks into the best high power density motors in the global market. Its power density is very high - 8-9 kW/kg. EMRAX motors have best-in-class power density. Mechanical and no load electrical losses are very small, so EMRAX can run on high RPM – in this case we can achieve very high motor power (up to 300 kWp – e.g. EMRAX 348 type). EMRAX motors use less material more efficiently to provide higher power densities than any comparable motor or generator.

Though many intensive tests that have already been made and though parts that have been produced by modern CNC machines, the motor is still not a real series product. Many manufacturing processes are still made by hand, what makes every drive unique. Therefore, our customers are and they will be part of a field test and we are already excited which experiences they make with the new motor.

EMRAX engines are being sold from year 2008. Through years of experiences we made many improvements. Development is never ending story, so there still will be improvements made. The customer assumes responsibility to share experiences made with the drive with the manufacturer, so that the manufacturer can gather know-how and identify possible weaknesses.

The usage of EMRAX motors is in automotive, motorsport, off road, marine, industrial, aerospace applications.

The orders are rising monthly, so we are prepared to raise the production quantity by multiplying the existing production cells and also to start mass production. Even though motors are not made in high volumes the advanced materials and proprietary construction techniques enable significant customer cost benefits. Therefore EMRAX motors have very competitive price in their class.

Applications where EMRAX motors can be used:

- Traction motors for on, off-road, rail and marine transport (hybrid or full electric).
- Generators (especially where size and weight are important).
- Integrated starter Generators (ISG) (start, generate and power boos from a small volume).
- Hydraulic replacement (compact and efficient alternatives for hydraulic motors and starters).



Figure 1: EMRAX testing in Letrika d.d. company

1. Technical data of EMRAX motors

EMRAX motors/generators are **advanced axial flux synchronous (BLAC) electric motors/generators**. EMRAX motors are available in a range of torque and speed combinations and with variety of cooling options. EMRAX motor types (the number in the name means the diameter of the motor in mm):

EMRAX 188: is being developed. It will be available for selling at the end of 2016. Orders are being collected.

- High Voltage (Air Cooled / Liquid Cooled (IP65) / Combined Cooled (IP21)
- Medium Voltage (Air Cooled / Liquid Cooled (IP65) / Combined Cooled (IP21)
- Low Voltage (Air Cooled / Liquid Cooled (IP65) / Combined Cooled (IP21)

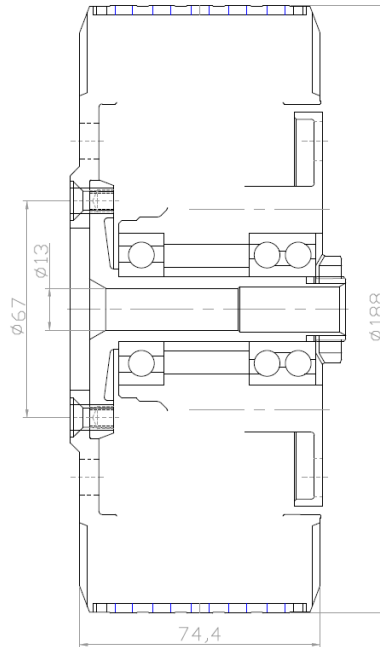

EMRAX 188:
100Nmp 70kWp at 6000RPM; weight: 7,5kg

Bearings 62046204 - Front and back bearing are for radial forces (standard).
Bearings 62047204 - Front bearing is for radial forces, back bearing is for axial-radial forces. Bearing combination is for pull mode (for e.g. air propeller).
Bearings 62043204 - Front bearing is for radial forces, back bearing is for axial-radial forces. Bearing combination is for pull-push mode. "D" bearing orientation.

Figure 2: EMRAX 188 side view

EMRAX 208: In production.

- High Voltage (Air Cooled / Liquid Cooled (IP65) / Combined Cooled (IP21)
- Medium Voltage (Air Cooled / Liquid Cooled (IP65) / Combined Cooled (IP21)
- Low Voltage (Air Cooled / Liquid Cooled (IP65) / Combined Cooled (IP21)

EMRAX 228: In production.

- High Voltage (Air Cooled / Liquid Cooled (IP65) / Combined Cooled (IP21)
- Medium Voltage (Air Cooled / Liquid Cooled (IP65) / Combined Cooled (IP21)
- Low Voltage (Air Cooled / Liquid Cooled (IP65) / Combined Cooled (IP21)

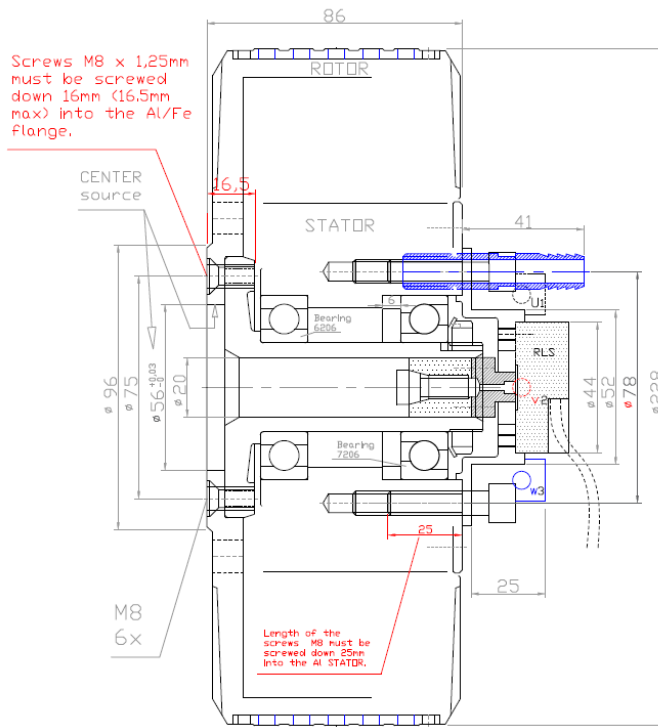

EMRAX 228
240 Nmp 100kW 12,5kg

Bearings 6206/6206 - Front and back bearing are for radial forces (standard).
 Bearings 6206/7206 - Front bearing is for radial forces, back bearing is for axial-radial forces. Bearing combination is for pull mode (For e.g. air propeller).
 Bearings 6206/3206 - Front bearing is for radial forces, back bearing is for axial-radial forces. Bearing combination is for pull-push mode. 'D' bearing orientation.

Figure 3: EMRAX 228 side view

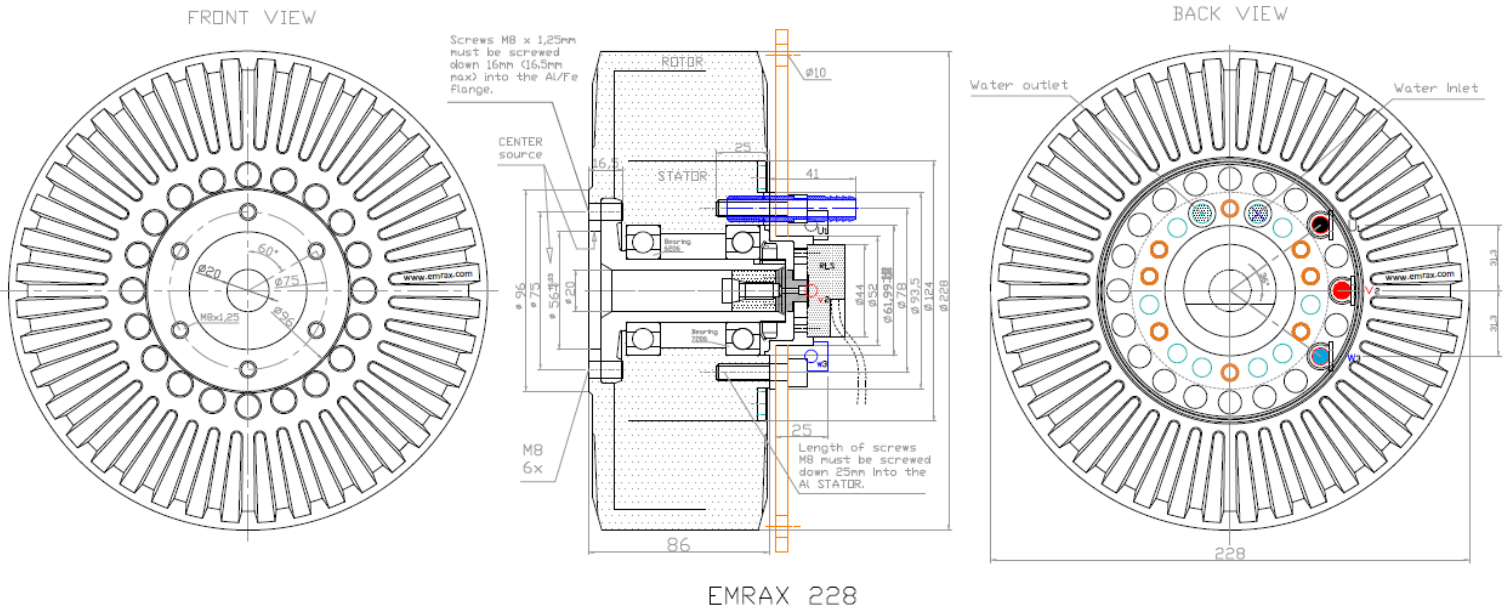

EMRAX 228

Figure 4: EMRAX 228 front, back, side view

EMRAX 268: In production.

- High Voltage (Air Cooled / Liquid Cooled (IP65) / Combined Cooled (IP21)
- Medium Voltage (Air Cooled / Liquid Cooled (IP65) / Combined Cooled (IP21)
- Low Voltage (Air Cooled / Liquid Cooled (IP65) / Combined Cooled (IP21)

*Customisations: EMRAX 268 Very High Mechanical Loads (VHML)

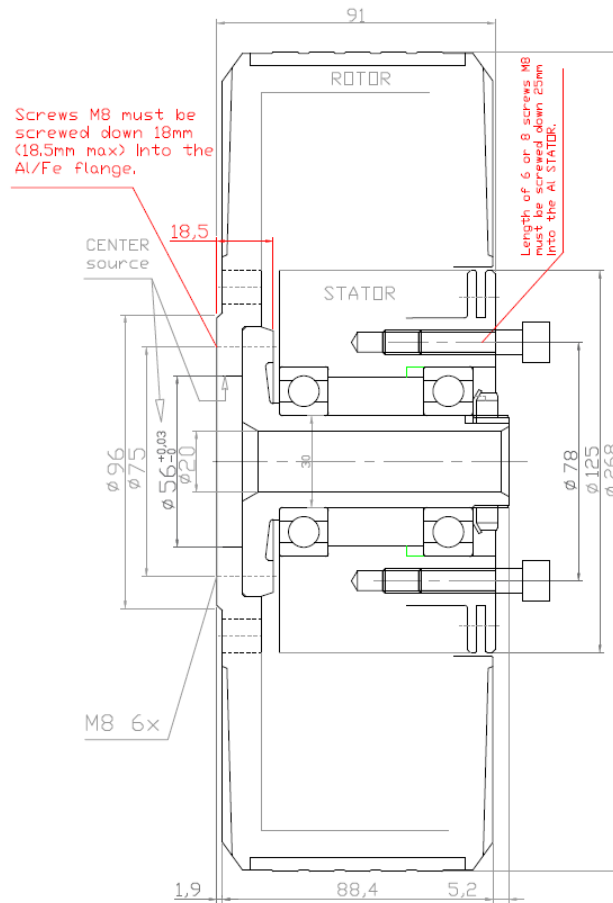

EMRAX 268

500Nmp 160kW 20kg

Bearings 6206/6206 - Front and back bearing are for radial forces (standard).
 Bearings 6206/7206 - Front bearing is for radial forces, back bearing is for axial-radial forces. Bearing combination is for pull mode (for e.g. air propeller).
 Bearings 6206/3206 - Front bearing is for radial forces, back bearing is for axial-radial forces. Bearing combination is for pull-push mode. "O" bearing orientation.

Figure 5: EMRAX 268 side view

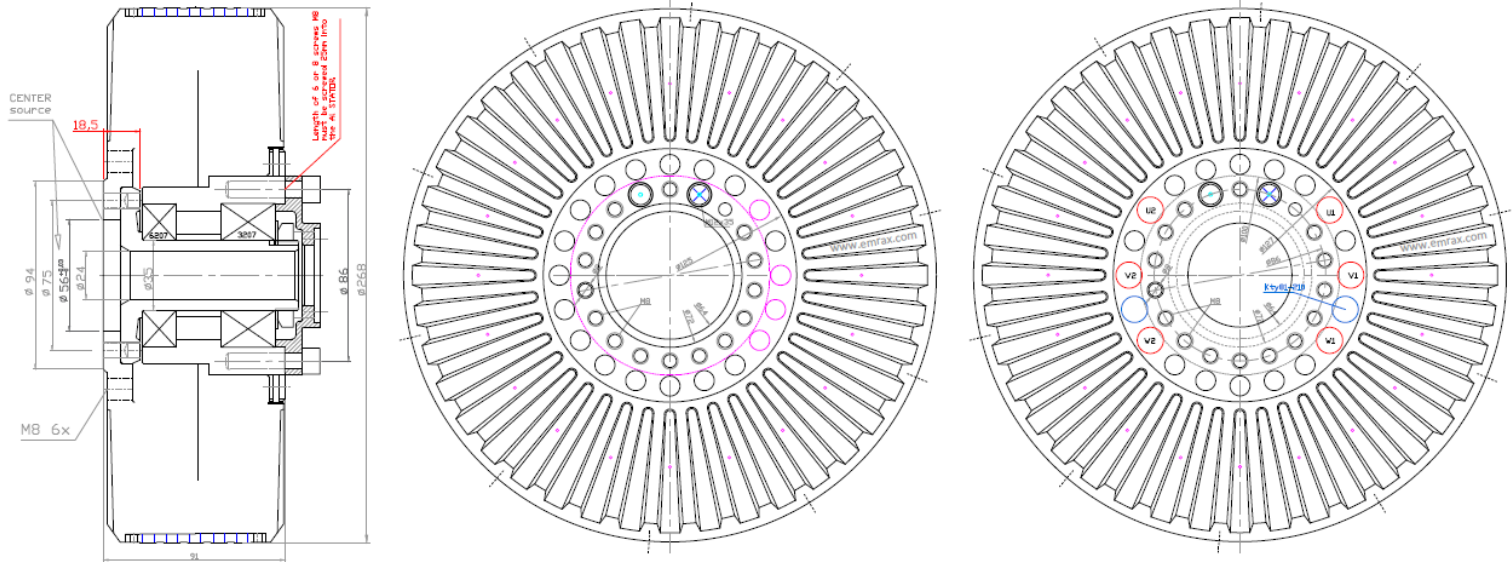

EMRAX 268 Very High Mechanical Loads (VHML)

500Nmp 160kW 21kg; stronger bearings and stronger motor shaft;
low voltage motor type can only be made with doubled phase
connectors (2xUVW) on the back side.

Bearings 6207/6207 - Front and back bearing are for radial forces (standard)
Bearings 6817/6207 - Front bearing is for radial forces, back bearing is for
axial-radial forces. Bearing combination is for pull mode (or slip air propellers)
Bearings 6817/6207 - Front bearing is for radial forces, back bearing is for
axial-radial forces. Bearing combination is for pull-push mode. 'D' bearing
orientation.

Figure 6: EMRAX 268 VHML front, back, side view

EMRAX 348: Prototype is being tested. It will be available for selling at the end of 2016. Orders are being collected.

- High Voltage (Air Cooled / Liquid Cooled (IP65) / Combined Cooled (IP21)
- Medium Voltage (Air Cooled / Liquid Cooled (IP65) / Combined Cooled (IP21)
- Low Voltage (Air Cooled / Liquid Cooled (IP65) / Combined Cooled (IP21)

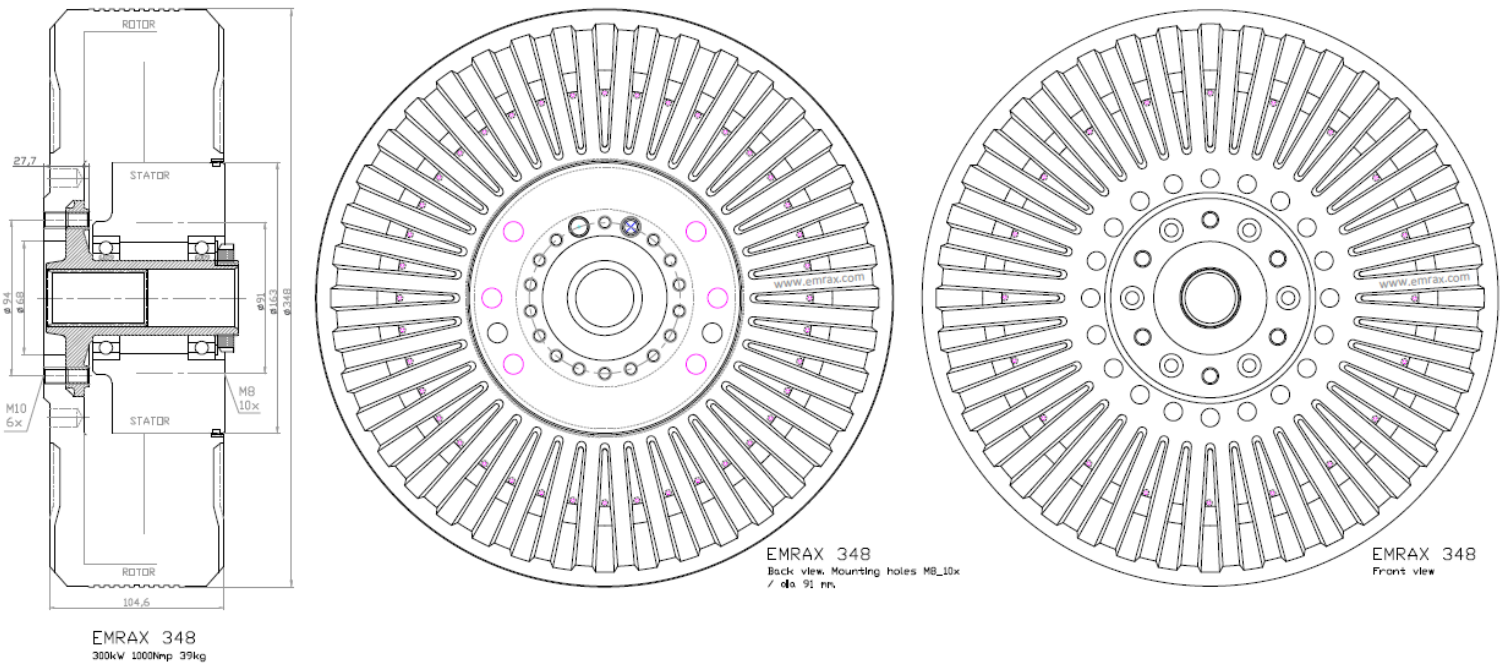

Figure 7: EMRAX 348 front, back, side view

CUSTOM MADE EMRAX MOTORS

- Customized winding:

For different voltages: Low-Medium Voltage (LMV)

For different speeds (RPM): for very low speeds and high torque at low motor current

- Customized motor shaft:

Hollow shaft with bigger diameter of the hole

Shaft with multi splines

- Special bearings for different magnitude and orientation of the force

- Doubled phase connectors (UVW):

One motor can be fitted with two controllers to get enough motor current. In this case motor has also redundancy option.

- Longer phase connectors (UVW): up to 150 mm

- Phase connectors on the opposite side (on the left side instead on the right side)

- Customized weight: lighter motors

EMRAX 188 Technical Data Table

It will be available for selling at the end of 2016. Orders are being collected.

Type	EMRAX 188 High Voltage			EMRAX 188 Medium Voltage			EMRAX 188 Low Voltage		
Technical data									
Air cooled = AC Liquid cooled = LC Combined cooled = Air + Liquid cooled = CC	AC	LC	CC	AC	LC	CC	AC	LC	CC
Ingress protection	IP21	IP65	IP21	IP21	IP65	IP21	IP21	IP65	IP21
Cooling medium specification (Air Flow = AF; Inlet Water/glycol Flow = WF; Ambient Air = AA) If inlet WF temperature and/or AA temperature are lower, then continuous power is higher.	AF=20m/s; AA=25°C	WF=8l/min at 50°C; AA=25°C	WF=8l/min at 50°C; AA=25°C	AF=20m/s; AA=25°C	WF=8l/min at 50°C; AA=25°C	WF=8l/min at 50°C; AA=25°C	AF=20m/s; AA=25°C	WF=8l/min at 50°C; AA=25°C	WF=8l/min at 50°C; AA=25°C
Weight [kg]	7,2	7,4	7,4	7,2	7,4	7,4	7,2	7,4	7,4
Diameter ϕ / width [mm]	188 / 77								
Maximal battery voltage [Vdc] and full load/no load RPM	350 Vdc (5950/7700 RPM)			230 Vdc (6210/7700 RPM)			90 Vdc (7200/7900 RPM)		
Peak motor power at max RPM (few min at cold start / few seconds at hot start) [kW]	70								
Continuous motor power (at 3000-6000 RPM) depends on the motor RPM [kW]	15 - 28	15 - 30	17 - 32	15 - 28	15 - 30	17 - 32	15 - 28	15 - 30	17 - 32
Maximal rotation speed [RPM]	6000 (7700 peak for a few seconds)								
Maximal motor current (for 2 min if cooled as described in Manual) [Arms]	200			320			800		
Continuous motor current [Arms]	100			160			400		
Maximal peak motor torque [Nm]	100								
Continuous motor torque [Nm]	50								
Torque / motor current [Nm/1Aph rms]	0,50			0,32			0,12		
Maximal temperature of the copper windings in the stator and max. temperature of the magnets [°C]	120								
Motor efficiency [%]	92-98%								
Internal phase resistance at 25 °C [m Ω]	/			/			/		
Input phase wire cross-section [mm ²]	10,2			15,2			38		
Wire connection	star								
Induction Ld/Lq [μ H]	/			/			/		
Controller / motor signal	sine wave								
AC voltage between two phases [Vrms/1RPM]	/			/			/		
Specific idle speed (no load RPM) [RPM/1Vdc]	22			33			88		
Specific load speed (depends on the controller settings) [RPM/1Vdc]	17 – 22			27 – 33			80 – 88		
Magnetic field weakening (for higher RPM at the same power and lower torque) [%]	up to 100								
Magnetic flux – axial [Vs]	/			/			/		
Temperature sensor in the motor	kty 81/210								
Number of pole pairs	10								
Rotor Inertia (mass dia=160mm, m=4,0kg) [kg*cm ²]	/								
Bearings (front:back) - SKF/FAG	6204:6204 (for radial forces) or 6204:7204 (for axial-radial forces; for pull mode; e.g. for air propeller) or 6204:3204 (for axial-radial forces; for pull-push mode; »O« orientation, $\alpha=25^\circ$); other bearings are possible (exceptionally)								

*Graphs for EMRAX 188 will be made in the end of 2016.

EMRAX 208 Technical Data Table (dynamometer test data)

Type	EMRAX 208 High Voltage			EMRAX 208 Medium Voltage			EMRAX 208 Low Voltage		
Technical data									
Air cooled = AC Liquid cooled = LC Combined cooled = Air + Liquid cooled = CC	AC	LC	CC	AC	LC	CC	AC	LC	CC
Ingress protection	IP21	IP65	IP21	IP21	IP65	IP21	IP21	IP65	IP21
Cooling medium specification (Air Flow = AF; Inlet Water/glycol Flow = WF; Ambient Air = AA) If inlet WF temperature and/or AA temperature are lower, then continuous power is higher.	AF=20m/s; AA=25°C	WF=8l/min at 50°C; AA=25°C	WF=8l/min at 50°C; AA=25°C	AF=20m/s; AA=25°C	WF=8l/min at 50°C; AA=25°C	WF=8l/min at 50°C; AA=25°C	AF=20m/s; AA=25°C	WF=8l/min at 50°C; AA=25°C	WF=8l/min at 50°C; AA=25°C
Weight [kg]	9,1	9,4	9,3	9,1	9,4	9,3	9,1	9,4	9,3
Diameter ϕ / width [mm]	208 / 85								
Maximal battery voltage [Vdc] and full load/no load RPM	470 Vdc (5170/7050 RPM)			320 Vdc (5760/7040 RPM)			125 Vdc (6250/7250 RPM)		
Peak motor power at max RPM (few min at cold start / few seconds at hot start) [kW]	80								
Continuous motor power (at 3000-5000 RPM) depends on the motor RPM [kW]	20 - 32	20 - 32	25 - 40	20 - 32	20 - 32	25 - 40	20 - 32	20 - 32	25 - 40
Maximal rotation speed [RPM]	6000 (7000 peak for a few seconds)								
Maximal motor current (for 2 min if cooled as described in Manual) [Arms]	200			320			800		
Continuous motor current [Arms]	100			160			400		
Maximal peak motor torque [Nm]	150								
Continuous motor torque [Nm]	80								
Torque / motor current [Nm/1Aph rms]	0,83			0,54			0,20		
Maximal temperature of the copper windings in the stator and max. temperature of the magnets [°C]	120								
Motor efficiency [%]	92-98%								
Internal phase resistance at 25 °C [m Ω]	12,0			5,7			0,8		
Input phase wire cross-section [mm ²]	10,2			15,2			38		
Wire connection	star								
Induction Ld/Lq [μ H]	125/130			52/56			7,2/7,5		
Controller / motor signal	sine wave								
AC voltage between two phases [Vrms/1RPM]	0,0487			0,0319			0,0117		
Specific idle speed (no load RPM) [RPM/1Vdc]	15			22			58		
Specific load speed (depends on the controller settings) [RPM/1Vdc]	11 – 15			18 – 22			50 – 58		
Magnetic field weakening (for higher RPM at the same power and lower torque) [%]	up to 100								
Magnetic flux – axial [Vs]	0,0393			0,0257			0,095		
Temperature sensor in the motor	kty 81/210								
Number of pole pairs	10								
Rotor Inertia (mass dia=160mm, m=4,0kg) [kg*cm ²]	256								
Bearings (front:back) - SKF/FAG	6206:6206 (for radial forces) or 6206:7206 (for axial-radial forces; for pull mode; e.g. for air propeller) or 6206:3206 (for axial-radial forces; for pull-push mode; »O« orientation, $\alpha=25^\circ$); other bearings are possible (exceptionally)								

Graphs valid for EMRAX High Voltage Combined Cooled (CC) motor type:

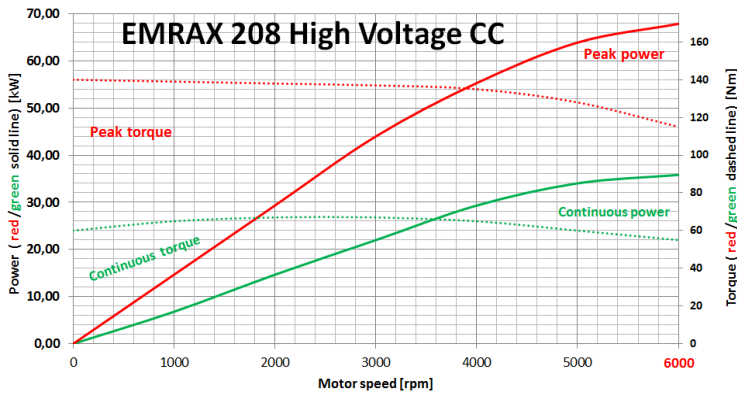

Note 1: for determining peak or continuous power (kW) you should choose motor speed and then read power from chosen power curve (in the left graph side)
 Note 2: for determining peak or continuous torque (Nm) you should choose motor speed and then read torque from chosen torque curve (in the right graph side)

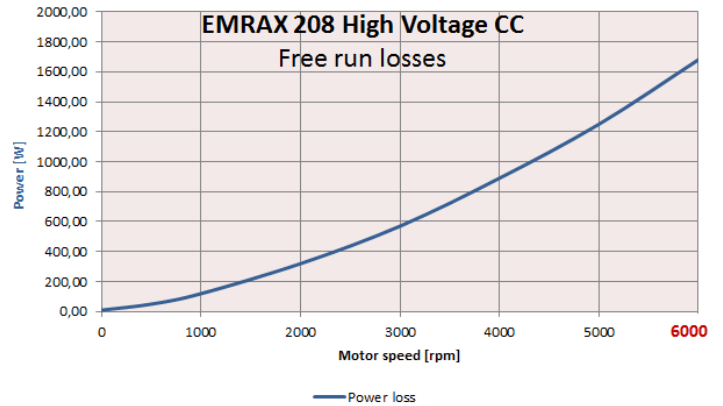
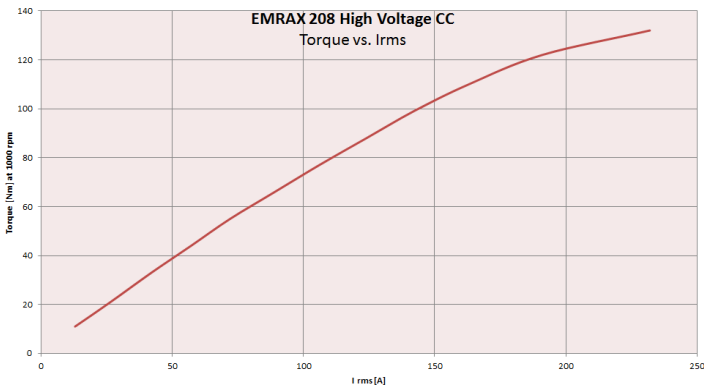
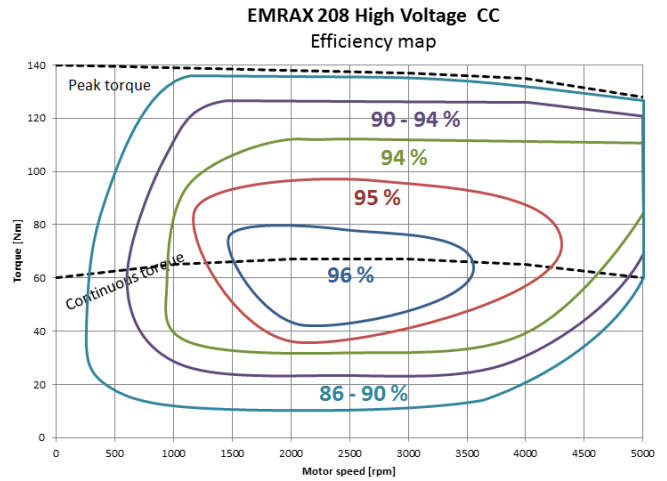

Graphs for EMRAX 208 Medium and Low voltage motor type:

Graphs for EMRAX 208 Low Voltage and EMRAX 208 Medium Voltage are similar to graphs for EMRAX 208 High Voltage. The only differences are in DC voltage and motor current. These two parameters can be read from the Technical data table for EMRAX 208 Low and Medium Voltage motor.

Low Voltage motor needs 4 x higher motor current and 4 x lower DC voltage for the same power/torque and RPM, compared to EMRAX 208 High Voltage motor.

Medium Voltage motor needs 1.52 x higher motor current and 1/3 lower DC voltage for the same power/torque and RPM, compared to EMRAX 208 High Voltage motor.

Graphs for EMRAX 208 Liquid cooled (LC) and EMRAX 208 Air Cooled (CC):

Continuous power of liquid cooled or air cooled motor is 20% lower than continuous power of combined cooled motor. Peak power is the same. Data is presented in technical data table.

EMRAX 228 Technical Data Table (dynamometer test data)

Type	EMRAX 228 High Voltage			EMRAX 228 Medium Voltage			EMRAX 228 Low Voltage		
Technical data									
Air cooled = AC Liquid cooled = LC Combined cooled = Air + Liquid cooled = CC	AC	LC	CC	AC	LC	CC	AC	LC	CC
Ingress protection	IP21	IP65	IP21	IP21	IP65	IP21	IP21	IP65	IP21
Cooling medium specification (Air Flow = AF; Inlet Water/glycol Flow = WF; Ambient Air = AA) If inlet WF temperature and/or AA temperature are lower, then continuous power is higher.	AF=20m/s ; AA=25°C	WF=8l/min at 50°C; AA=25°C	WF=8l/min at 50°C; AA=25°C	AF=20m/s ; AA=25°C	WF=8l/min at 50°C; AA=25°C	WF=8l/min at 50°C; AA=25°C	AF=20m/s ; AA=25°C	WF=8l/min at 50°C; AA=25°C	WF=8l/min at 50°C; AA=25°C
Weight [kg]	12,0	12,3	12,3	12,0	12,3	12,3	12,0	12,3	12,3
Diameter ϕ / width [mm]	228/86								
Maximal battery voltage [Vdc] and full load/no load RPM	670 Vdc (5300/6500 RPM)			470 Vdc (5170/6500 RPM)			130 Vdc (4400/5200 RPM)		
Peak motor power at max RPM (few min at cold start / few seconds at hot start) [kW]	100								
Continuous motor power (at 3000-5000 RPM) depends on the motor RPM [kW]	28 - 42	28 - 42	35 - 55	28 - 42	28 - 42	35 - 55	28 - 42	28 - 42	35 - 55
Maximal rotation speed [RPM]	5500 (6500 RPM peak for a few seconds)								
Maximal motor current (for 2 min if cooled as described in Manual) [Arms]	240			340			900		
Continuous motor current [Arms]	115			160			450		
Maximal motor torque (for a few seconds) [Nm]	240								
Continuous motor torque [Nm]	125								
Torque / motor current [Nm/1Aph rms]	1,1			0,75			0,27		
Maximal temperature of the copper windings in the stator and max. temperature of the magnets [°C]	120								
Motor efficiency [%]	92 – 98								
Internal phase resistance at 25 °C [m Ω]	18			8,0			1,12		
Input phase wire cross-section [mm ²]	10,2			15,2			38		
Wire connection	star								
Induction in Ld/Lq [μ H]	177/183			76/79			10,3/10,6		
Controller / motor signal	sine wave								
AC voltage between two phases [Vrms/1RPM]	0,0730			0,0478			0,0176		
Specific idle speed (no load RPM) [RPM/1Vdc]	9,8			14			40		
Specific load speed (depends on the controller settings) [RPM/1Vdc]	8 – 9,8			11 – 14			34 – 40		
Magnetic field weakening (for higher RPM at the same power and lower torque) [%]	up to 100								
Magnetic flux – axial [Vs]	0,0542			0,0355			0,0131		
Temperature sensor in the motor	kty 81/210								
Number of pole pairs	10								
Rotor inertia (mass dia=175mm, m=5,5kg) [kg*cm ²]	421								
Bearings Bearings (front:back) - SKF/FAG	6206:6206 (for radial forces) or 6206:7206 (for axial-radial forces; for pull mode; e.g. for air propeller) or 6206:3206 (for axial-radial forces; for pull-push mode; »O« orientation, $\alpha=25^\circ$); other bearings are possible (exceptionally)								

Graphs valid for EMRAX 228 High Voltage Combined Cooled (CC):

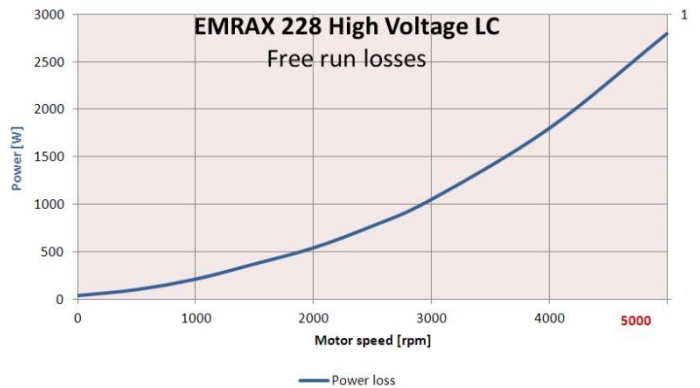
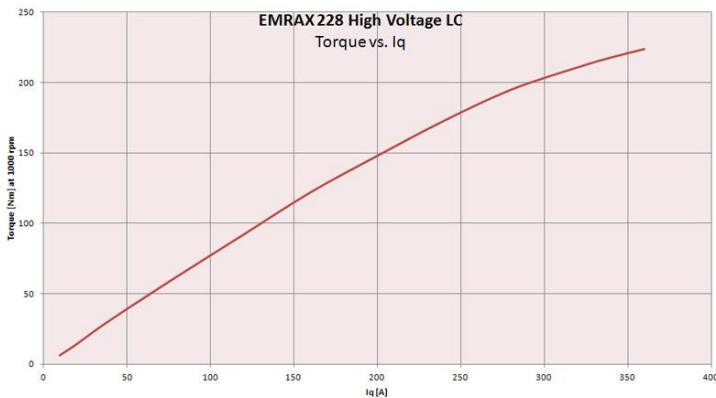
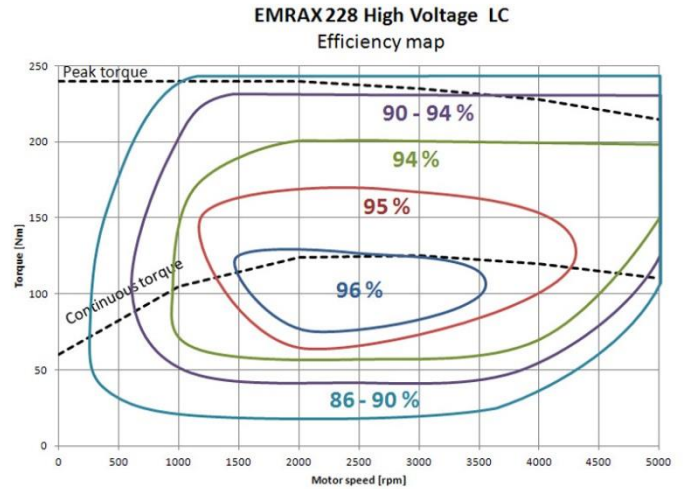
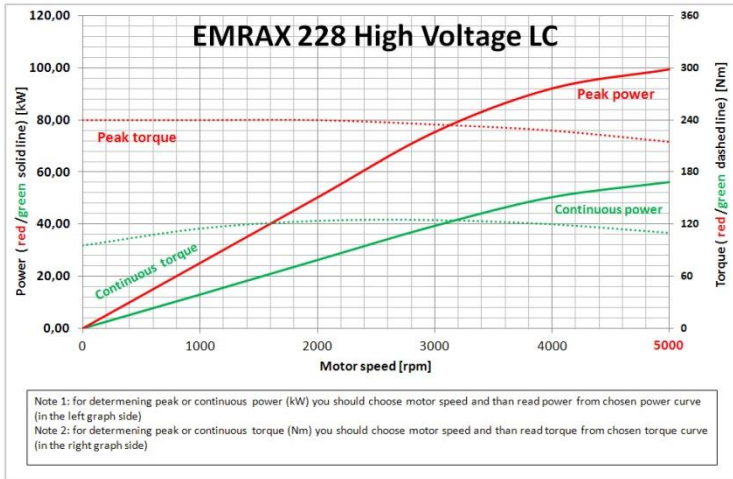

Graphs for EMRAX 228 Medium and Low voltage motor type:

Graphs for EMRAX 228 Low Voltage and EMRAX 228 Medium Voltage are similar to graphs for EMRAX 228 High Voltage. The only differences are in DC voltage and motor current. These two parameters can be read from the Technical data table for EMRAX 228 Low and Medium Voltage motor.

Low Voltage motor needs 4 x higher current and 4 x lower DC voltage for the same power/torque and RPM, compared to EMRAX 228 High Voltage motor.

Medium Voltage motor needs 1.52 x higher motor current and 1/3 lower DC voltage for the same power/torque and RPM, compared to EMRAX 228 High Voltage motor.

Graphs for EMRAX 228 Liquid cooled (LC) and EMRAX 228 Air Cooled (CC):

Continuous power of liquid cooled or air cooled motor is 20% lower than continuous power of combined cooled motor. Peak power is the same. Data is presented in technical data table.

EMRAX 268 Technical Data Table (dynamometer test data)

Technical data	EMRAX 268 High Voltage			EMRAX 268 Medium Voltage			EMRAX 268 Low Voltage or EMRAX 268 Low Voltage**		
	AC	LC	CC	AC	LC	CC	AC	LC	CC
Air cooled = AC Liquid cooled = LC Combined cooled = Air + Liquid cooled = CC									
Ingress protection	IP21	IP65	IP21	IP21	IP65	IP21	IP21	IP65	IP21
Cooling medium specification (Air Flow = AF; Inlet Water/glycol Flow = WF; Ambient Air = AA) If inlet WF temperature and/or AA temperature are lower, then continuous power is higher.	AF=20m/s; AA=25°C	WF=8l/min at 50°C; AA=25°C	WF=8l/min at 50°C; AA=25°C	AF=20m/s; AA=25°C	WF=8l/min at 50°C; AA=25°C	WF=8l/min at 50°C; AA=25°C	AF=20m/s; AA=25°C	WF=8l/min at 50°C; AA=25°C	WF=8l/min at 50°C; AA=25°C
Weight [kg]	19,9	20,3	20,3	19,9	20,3	20,3	19,9	20,3	20,3
Diameter ϕ / width [mm]	268/91								
Maximal battery voltage [Vdc] and full load/no load RPM	700 Vdc (3200/3800 RPM)			680 Vdc (4700/5500 RPM)			130 Vdc (2300/2900 RPM) 250 Vdc (4500/5500 RPM)		
Peak motor power at max RPM (few min at cold start / few seconds at hot start) [kW]	160			230			115 (at 2300 RPM load); 220 (at 4500 RPM load)		
Continuous motor power (at 2000-4000 RPM) depends on the motor RPM [kW]	40 - 75	40 - 80	50 - 85	40 - 80	40 - 90	50 - 110	40 - 75	40 - 80	50 - 90
Maximal rotation speed [RPM]	4500 RPM (5500 RPM peak for a few seconds)								
Maximal motor current (for 2 min if it is cooled as described in Manual) [Arms]	270			400			1000		
Continuous motor current [Arms]	125			190			500		
Maximal motor torque (for a few seconds) [Nm]				500					
Continuous motor torque [Nm]				250					
Torque / motor current [Nm/1Aph rms]	2,0			1,4			0,5		
Maximal temperature of the copper windings in the stator and max. temperature of the magnets [°C]				120					
Motor efficiency [%]				92 - 98					
Internal phase resistance at 25 °C [m Ω]	26			11,5			1,7		
Input phase wire cross-section [mm ²]	10,2			15,2			38		
Wire connection	star								
Induction in Ld/Lq [μ H]	292/273			126/118			17/15,9		
Controller / motor signal	sine wave								
AC voltage between two phases [Vrms/1RPM]	0,2320			0,1520			0,0560		
Specific idle speed (no load RPM) [RPM/1Vdc]	5,4			8,2			22,2		
Specific load speed (depends on the controller settings) [RPM/1Vdc]	4,5 - 5,4			7 - 8,2			18 - 22,2		
Magnetic field weakening (for higher RPM at the same power and lower torque) [%]				up to 100					
Magnetic flux – axial [Vs]	0,1014			0,0664			0,0245		
Temperature sensor in the motor	kty 81/210								
Number of pole pairs	10								
Rotor inertia (mass dia=195mm, m=9,8kg) [kg*cm ²]	932								
Bearings (front:back) – SKF/FAG	6206:6206 (for radial forces) or 6206:7206 (for axial-radial forces; for pull mode; e.g. for air propeller) or 6206:3206 (for axial-radial forces; for pull-push mode; »O« orientation, $\alpha=25^\circ$); other bearings are possible (exceptionally)								
EMRAX 268 Very High Mechanical Loads (VHML)	stronger motor shaft and bearings (6207:6207 for radial forces)			stronger motor shaft and bearings (6207:7207 for axial-radial forces; for pull mode; e.g. for air propeller)			stronger motor shaft and bearings (6207:3207 for axial-radial forces; for pull-push mode; »O« orientation, $\alpha=25^\circ$)		

*EMRAX 268 VHML Low Voltage version always has 2 sequences of phase connectors (2x UVW).

**Controller for EMRAX 268 Low Voltage motor should have very high peak and continuous motor current (1000 Arms peak and 500 Arms continuous). It is difficult to find so high current controller in the global market. The most suitable is emDrive 500 from Emsiso company, which has 500 Arms continuous and 800 Arms peak motor current. Another possibility to get enough high motor current is to connect 1 motor with 2 controllers by using 2 set of phase connectors (2x UVW) on the motor.

Graphs valid for EMRAX 268 High Voltage Combined Cooled (CC):

Graphs were made from tests, which were made Letrika d.d. in 2014. Motor was tested only up to 400 Nm of torque, because the opposite generator on test bench generated only 400 Nm of torque. DC voltage from the batteries was only 400 V, so we were able to run EMRAX motor only on lower speed, than is the maximal motor speed. Motor was tested also with magnet field weakening setting in the controller – in this case we got much higher speed at the same power. Water/glycol flow was only 3,5 l/min, but it must be 6-8 l/min as it is written in Technical Data Table.

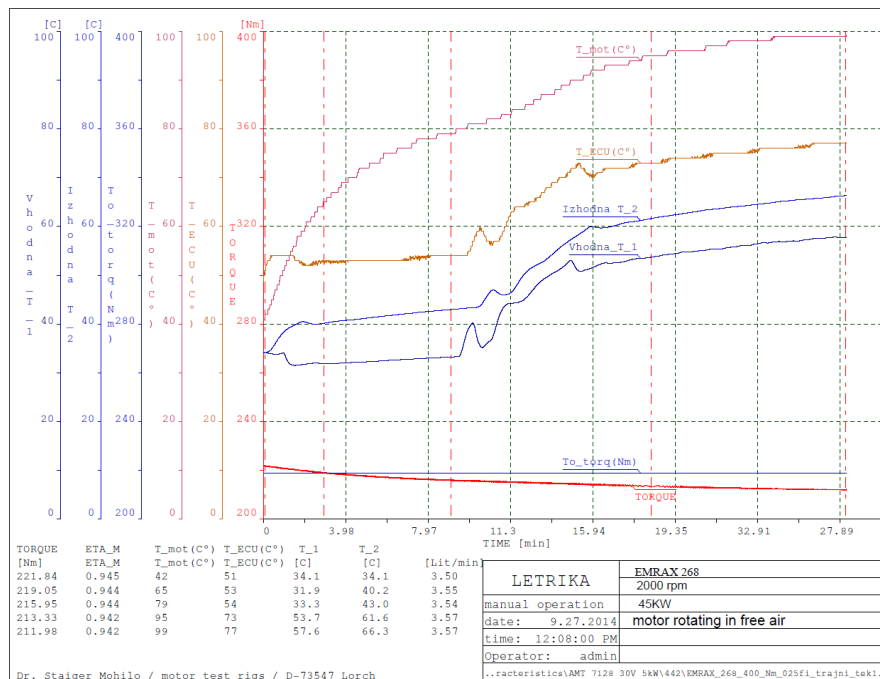
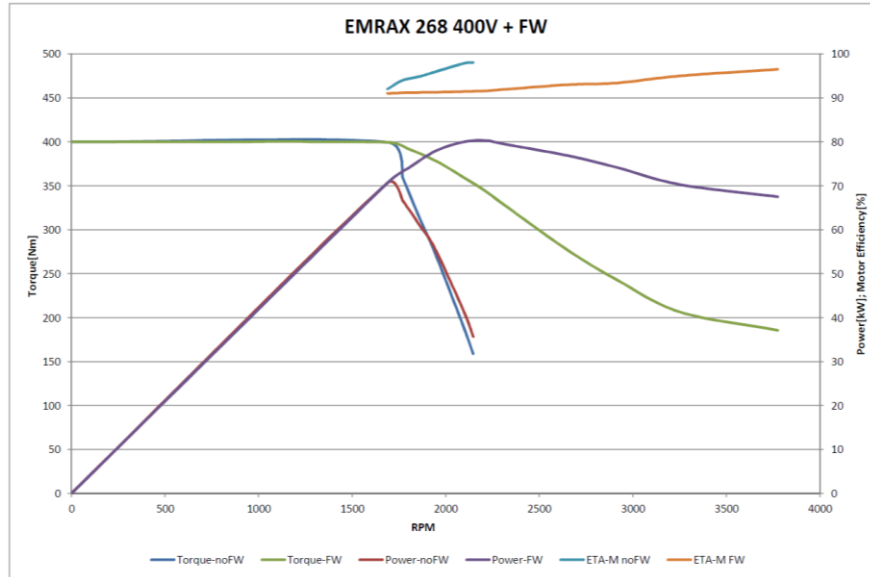

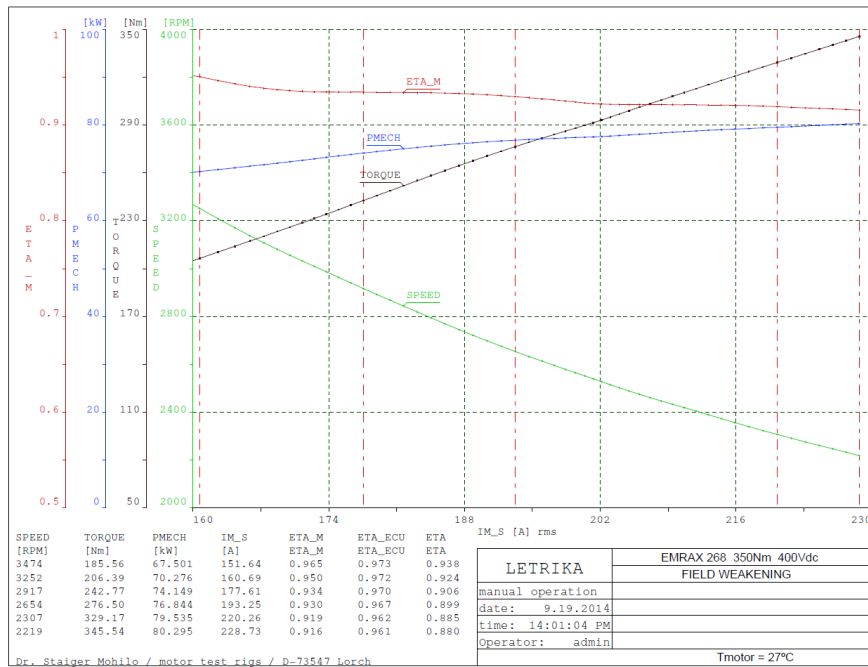
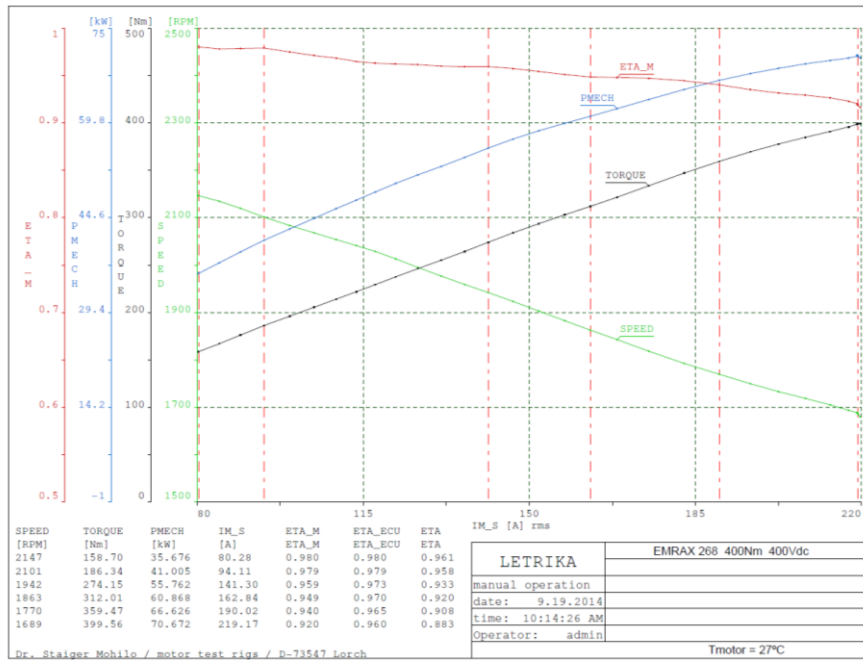

Graphs for EMRAX 268 Medium and Low voltage motor type:

Graphs for EMRAX 268 Low Voltage and EMRAX 268 Medium Voltage are similar to graphs for EMRAX 268 High Voltage. The only differences are in DC voltage and motor current. These two parameters can be read from the Technical data table for EMRAX 268 Low and Medium Voltage motor.

Low Voltage motor needs 4 x higher current and 4 x lower DC voltage for the same power/torque and RPM, compared to EMRAX 268 High Voltage motor.

Medium Voltage motor needs 1.52 x higher motor current and 1/3 lower DC voltage for the same power/torque and RPM, compared to EMRAX 268 High Voltage motor.

Graphs for EMRAX 268 Liquid cooled (LC) and EMRAX 268 Air Cooled (CC):

Continuous power of liquid cooled or air cooled motor is 20% lower than continuous power of combined cooled motor. Peak power is the same. Data is presented in technical data table.

EMRAX 348 Technical Data Table

It will be available for selling at the end of 2016. Orders are being collected.

Technical data	Type	EMRAX 348 High Voltage			EMRAX 348 Medium Voltage			EMRAX 348 Low Voltage		
		AC	LC	CC	AC	LC	CC	AC	LC	CC
Air cooled = AC Liquid cooled = LC Combined cooled = Air + Liquid cooled = CC										
Ingress protection		IP21	IP65	IP21	IP21	IP65	IP21	IP21	IP65	IP21
Cooling medium specification (Air Flow = AF; Water/glycol Flow = WF – if inlet water/glycol temperature and/or ambient temperature are lower, then continuous power is higher)		AF=20m/s ; AA=25°C	WF=8l/min at 50°C; AA=25°C	WF=8l/min at 50°C; AA=25°C	AF=20m/s ; AA=25°C	WF=8l/min at 50°C; AA=25°C	WF=8l/min at 50°C; AA=25°C	AF=20m/s ; AA=25°C	WF=8l/min at 50°C; AA=25°C	WF=8l/min at 50°C; AA=25°C
Weight [kg]		39	40	40	39	40	40	39	40	40
Diameter ϕ / width [mm]		348/107								
Maximal battery voltage [Vdc] and full load/no load RPM		800 Vdc (1800/2200 RPM)			800 Vdc (2800/3400 RPM)			130 Vdc (1200/1500 RPM) 340 Vdc (3200/4000 RPM)		
Peak motor power at max RPM (few min at cold start / few seconds at hot start) [kW]		190			290			125 kW (at 1200 RPM load #) 330 kW (at 3200 RPM load ##)		
Continuous motor power at load RPM [kW]		90	100	100	140	150	170	70 at #; 170 at ##	70 at #; 180 at ##	80 at #; 200 at ##
Maximal rotation speed [RPM]		4000 (with maximal battery voltage or magnetic field weakening)								
Maximal motor current (for 2 min if it is cooled as described in Manual) [Arms]		280			450			1100		
Continuous motor current [Arms]		140			210			550		
Maximal motor torque (for a few seconds) [Nm]		1000								
Continuous motor torque [Nm]		500								
Torque / motor current [Nm/1Aph rms]		3,8			2,5			0,9		
Cogging torque [Nm]		5								
Maximal temperature of the copper windings in the stator and max. temp. of the magnets [°C]		120								
Motor efficiency [%]		92 - 98								
Internal phase resistance at 25 °C [m Ω]		32			14			5		
Input phase wire cross-section [mm ²]		10,2			15,2			38		
Wire connection		star								
Induction in Ld/Lq [μ H]		418/452			180/195			24,3/26,3		
Controller / motor signal		sine wave								
AC voltage between two phases [Vrms/1RPM]		0,2320			0,1520			0,0560		
Specific idle speed (no load) [RPM/1Vdc]		2,8			4,3			11,8		
Specific - load speed (depends on the controller settings) [RPM/1Vdc]		2,3 – 2,8			3,5 – 4,3			9,5 – 11,8		
Magnetic field weakening (for higher RPM at the same power and lower torque) [%]		up to 100 %								
Magnetic flux – axial [Vs]		N/A			N/A			N/A		
Temperature sensor in the motor		kty 81/210								
Number of pole pairs		10								
Rotor inertia (mass dia=270 mm, m=20kg) [kg*cm ²]		N/A								
Bearings (front:back) – SKF/FAG		6009:6009 (for radial forces) for axial-radial forces contact EMRAX company								

*Controller for EMRAX 348 Low Voltage should have very high peak and continuous motor current (1100 Arms peak and 550 Arms continuous). It is difficult to find so high current controller on the global market. The most suitable would be emDrive 500 from Emsiso company, which has 500 Arms continuous and 800

Arms peak motor current. Another possibility to get enough high motor current is to connect 1 motor with 2 controllers by using 2 set of phase connectors (2x UWV) on the motor.

2. Intended usage of EMRAX motor/generator

Before selling EMRAX motor, every EMRAX is tested at standard ambient and motor cooling conditions (described in Technical data tables) in our company operating as a generator and as a motor with Unitek GmbH BAMOCAR D3 controller.

The drive is built according to the state of the art and to approved safety-related rules. However, risks for life and limb of the user or other parties as well as damages to the device or other material assets can arise.

Only use the system in technically soundness, safety-conscious, according to the intended usage and be aware of dangers! Especially faults which can affect the safety should be cleared immediately!

Do not to use the motor in salt environment directly.

Avoid full throttle idle running at higher voltages. Speed (motor rotation) must be limited in the controller SW according to Technical data table for each EMRAX type.

EMRAX motor must be used in accordance with ambient and motor cooling conditions, which are described in Technical data table for each EMRAX motor type, otherwise the warranty does not apply.

3. Motor types and additional motor parts

EMRAX motor family consists of 5 different motor sizes: 188 mm, 208 mm, 228 mm, 268 mm and 348 mm diameter. Each motor size can be air, combined or liquid cooled and also each of them can be made for high, medium or low voltage.

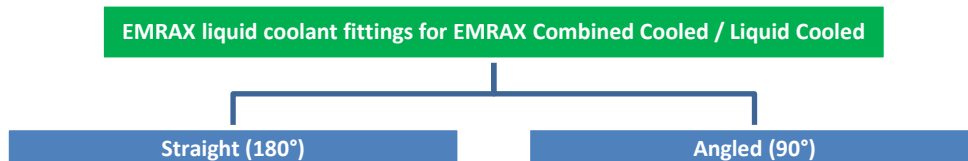
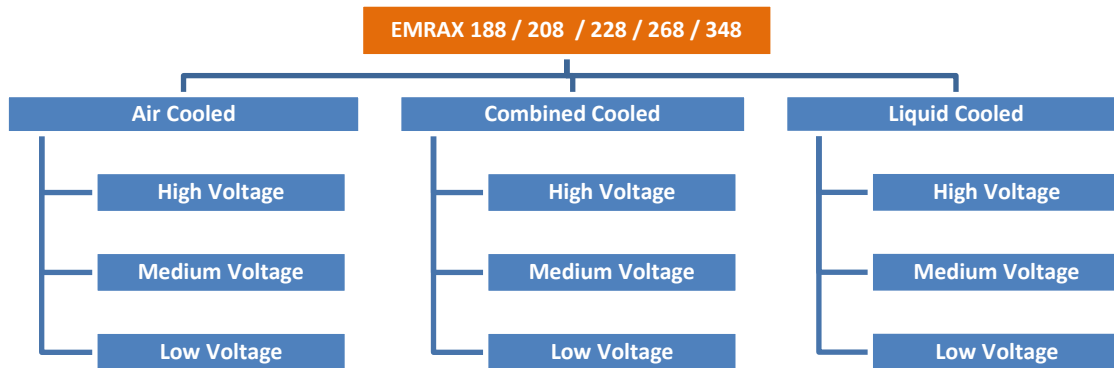

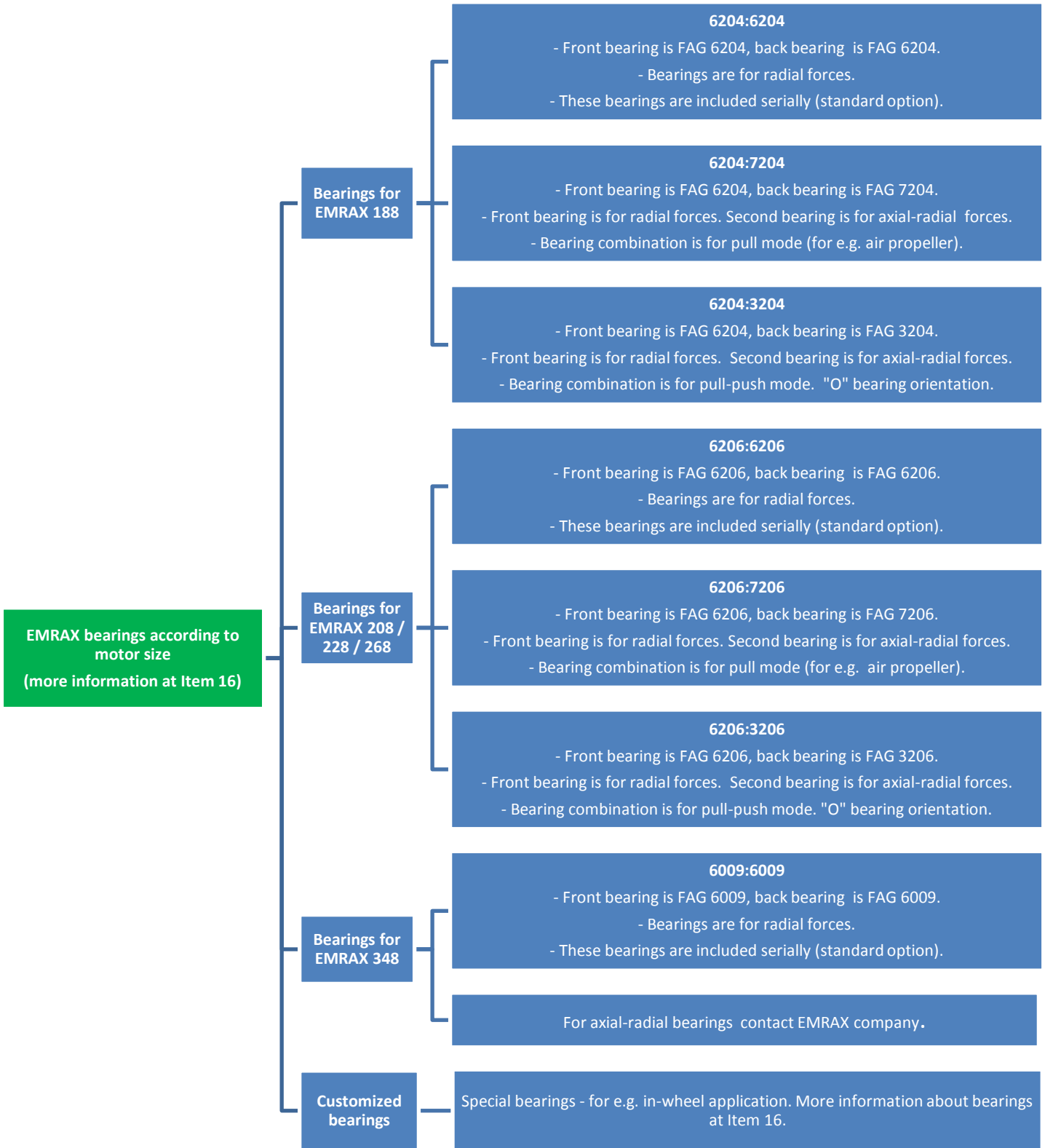

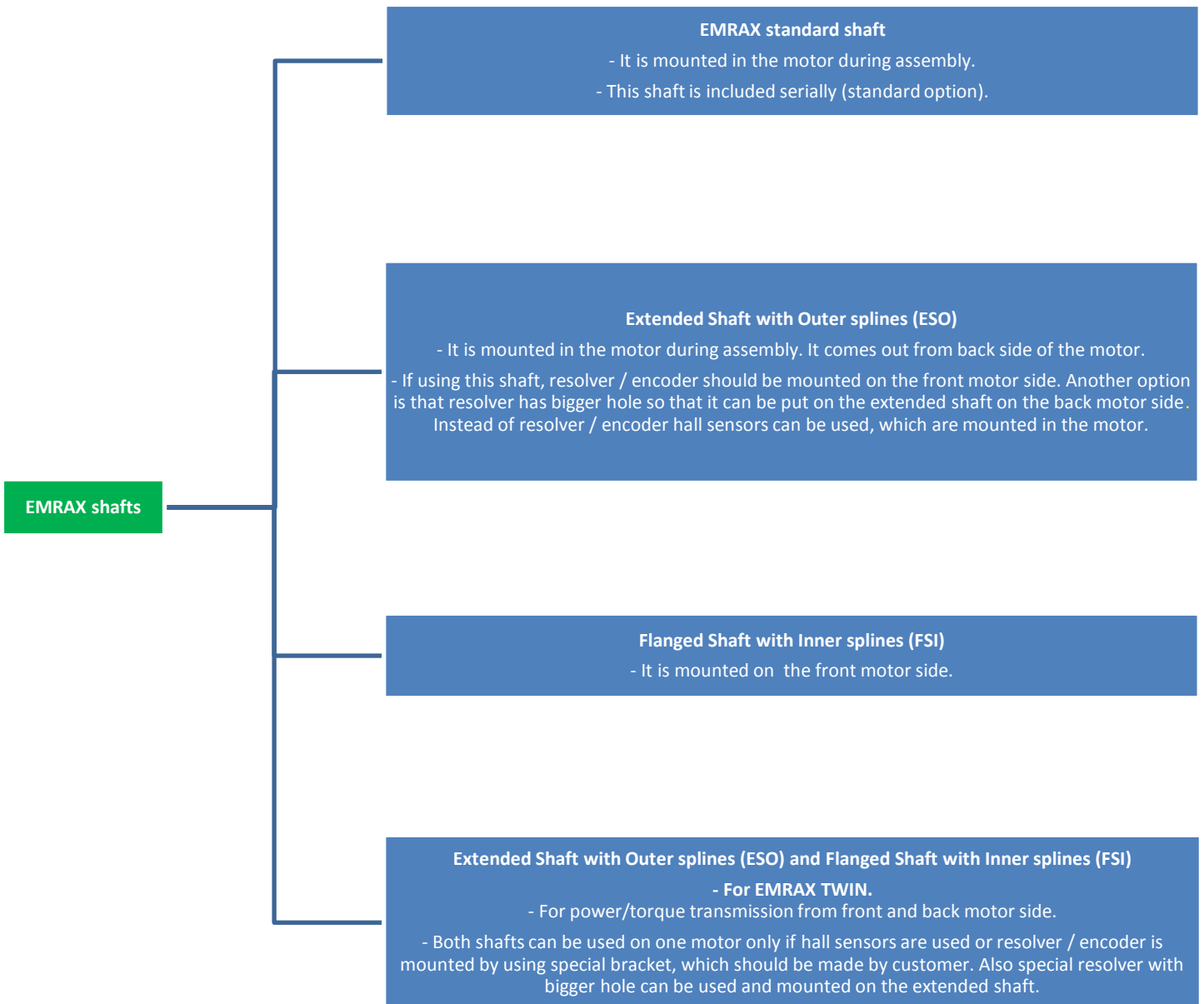
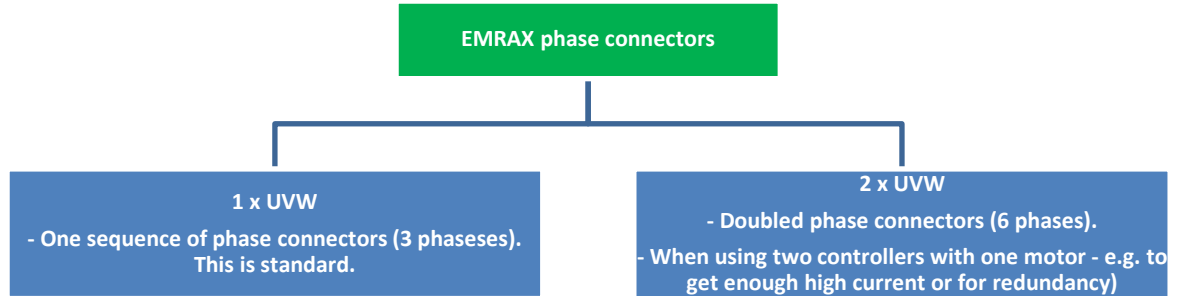

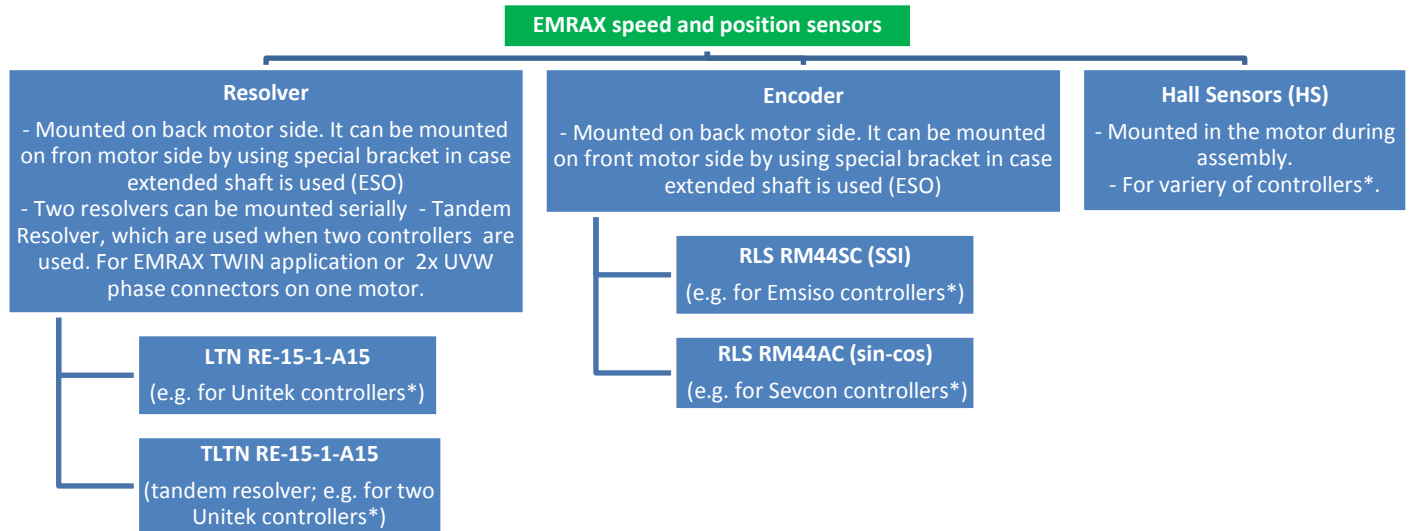

*For more information about suitable sensor for each controller contact the controller producer.

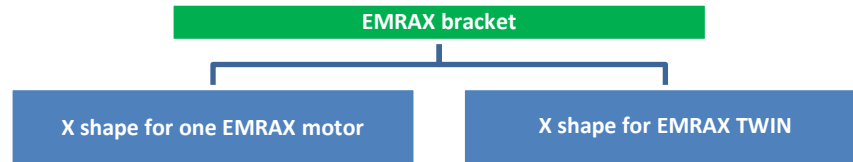

4. Order codes, tariff (HTS) codes, weights of EMRAX motors and additional motor parts

Sample of order code: EMRAX_228_HV_LC(IP65)_6206:7206_LTN_180

Item code:	Explanation:	Weight (kg)	Tariff (HTS) codes and description
EMRAX	Motor name		
188 / 208 / 228 / 268 / 348	Motor diameter in mm		
LV / MV / HV	Voltage type (Low Voltage / Medium Voltage / High Voltage)		
LC(IP65) / CC(IP21) / AC(IP21)	Liquid Cooled (IP65) / Combined Cooled (IP21) / Air Cooled (IP21)		
6204:6204	For EMRAX 188. Front bearing is FAG 6204, back bearing is FAG 6204. Bearings are for radial forces. These bearings are included serially (standard option).		
6204:7204	For EMRAX 188. Front bearing is FAG 6204, back bearing is FAG 7204. Front bearing is for radial forces. Second bearing is for axial-radial forces. Bearing combination is for pull mode.	7 / 9 / 12 / 20 / 40 <i>* EMRAX 188 and 348 will be ready for selling in the end of 2016.</i>	8501.52.9; electric motor
6204:3204	For EMRAX 188. Front bearing is FAG 6204, back bearing is FAG 3204. Front bearing is for radial forces. Second bearing is for axial-radial forces. Bearing combination is for pull-push mode.		
6206:6206	For EMRAX208/228/268. Front bearing is FAG 6206, back bearing is FAG 6206. Bearings are for radial forces. These bearings are included serially (standard option).		
6206:7206	For EMRAX208/228/268. Front bearing is FAG 6206, back bearing is FAG 7206. Front bearing is for radial forces. Second bearing is for axial-radial forces. Bearing combination is for pull mode.		
6206:3206	For EMRAX208/228/268. Front bearing is FAG 6206, back bearing is FAG 3206. Front bearing is for radial forces. Second bearing is for axial-radial forces. Bearing combination is for pull-push mode.		

6009:6009	For EMRAX 348. Front bearing is FAG 6009, back bearing is FAG 6009. Bearings are for radial forces. These bearings are included serially (standard option).		
2xUVWV	2 sequences of phase connectors (6 motor phases). When using one motor with two controllers to get enough high current.		
VHML	Bearings and motor shaft made for Very High Mechanical Loads (VHML). Stronger bearings and stronger shaft. Possible only for EMRAX 268.		
LTN(back)	Resolver LTN RE-15-1-A15 (e.g. for Unitek Bamocar D3 controller) with bracket mounted on back side of the motor.	0,2	9031.80.98; speed and position sensor
LTN(front)	Resolver LTN RE-15-1-A15 (e.g. for Unitek Bamocar D3 controller) with bracket mounted on front side of the motor. Mechanical connection between resolver bracket and motor bracket must be made by customer. EMRAX company can provide drawings.	0,3	
TLTN	Tandem resolver LTN RE-15-1-A15 (e.g. for two Unitek Bamocar D3 controllers) with bracket mounted on the back side of the motor. For EMRAX TWIN (mounted on back side of the second motor) and when using two controllers with one motor (in this case two sequences of phase connectors are needed; 2xUVWV).	0,3	
RLS RM44SC(back)	Encoder RLS RM44SC (SSI; e.g. for Emsiso controller) with bracket mounted on back side of the motor.	0,2	
RLS RM44SC(front)	Encoder RLS RM44SC (SSI; e.g. for Emsiso controller) with bracket mounted on front side of the motor. Mechanical connection between resolver bracket and motor bracket must be made by customer. EMRAX company can provide drawings.	0,3	
RLS RM44AC(back)	Encoder RLS RM44AC (sin-cos; e.g. for Sevcon controller) with bracket mounted on back side of the motor.	0,2	
RLS RM44AC(front)	Encoder RLS RM44AC (sin-cos; e.g. for Sevcon controller) with bracket mounted on front side of the motor. Mechanical connection between resolver bracket and motor bracket must be made by customer. EMRAX company can provide drawings.	0,3	
HS	Hall Sensors mounted inside the motor. Suitable for some other controllers; cable length is app 1m).	0,2	
180	Coolant fittings - 180° (straight tubes). Two in one package (for 1 motor).	0,1	7411.21.90; coolant fittings
90	Coolant fittings - 90° (angular tubes). Two in one package (for 1 motor).	0,1	
ESO	Extended motor Shaft with Outer splines comes out from back motor side (mounted in the motor during assembly). If using this shaft, resolver / encoder should be mounted on the front motor side. Another option is that resolver with bigger hole is put on the extended shaft on the back motor side. Instead of resolver / encoder hall sensors can be used, which are mounted in the motor.	1,1	8483.10.95; shaft
FSI	Flanged Shaft with Inner splines is mounted on front motor side.	0,6	
ESO and FSI	Extended motor Shaft with Outer splines comes out from back motor side (mounted in the motor during assembly) and Flanged Shaft with Inner splines is mounted on front motor side. For EMRAX TWIN. Both shafts can be used on one motor only if hall sensors are used or resolver / encoder is mounted by using special bracket, which should be made by customer. Also special resolver with bigger hole can be used and mounted on the extended shaft.	1,7	
X	X shaped iron bracket. For one motor 1 pc is needed. For EMRAX TWIN 2 pcs are needed.	1	7326.90.98; steel bracket

5. 3D drawings of EMRAX motors

EMRAX 3D drawings can be downloaded here: www.emrax.com

6. Mounting the motor

Only use the drive if properly mounted on eight (on the back side of the motor) M8 threaded bores destined for that in the stator (Figure 4, Figure 8). EMRAX has an external rotor, which must not at all, not even for trying, be connected to the frequency converter or the power source if the motor is not fixed in the way described above. Propeller, Flanged Shaft with Inner Splines (FSI) other some other drive shaft can be mounted on the front motor side with six M8 threaded bores destined for that in the rotor. These screws must be screwed down into the rotor:

- at least 14 mm and not more than 15 mm – for EMRAX 188 (M6 instead of M8 threaded boreholes)
- at least 15 mm and not more than 16,0 mm - for EMRAX 208
- at least 15,5 mm and not more than 16,5 mm - for EMRAX 228
- at least 17,5 mm and not more than 18,5 mm - for EMRAX 268
- at least 27 mm and not more than 28 mm – for EMRAX 348 (M10 instead of M8 threaded boreholes)

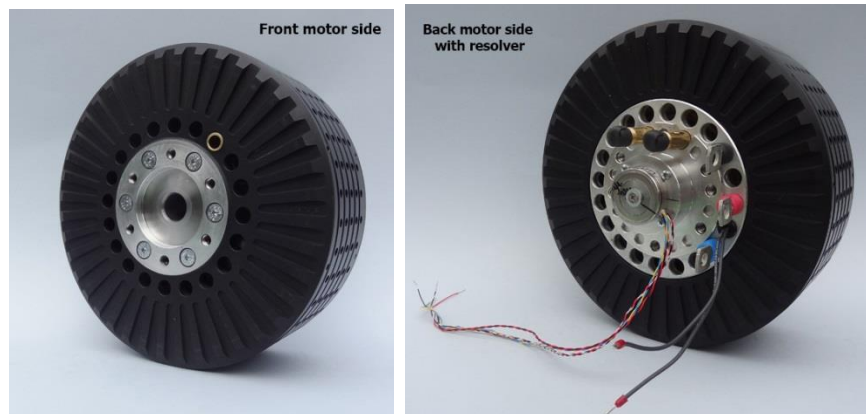

Figure 8: Mounting holed on front and back side of the motor

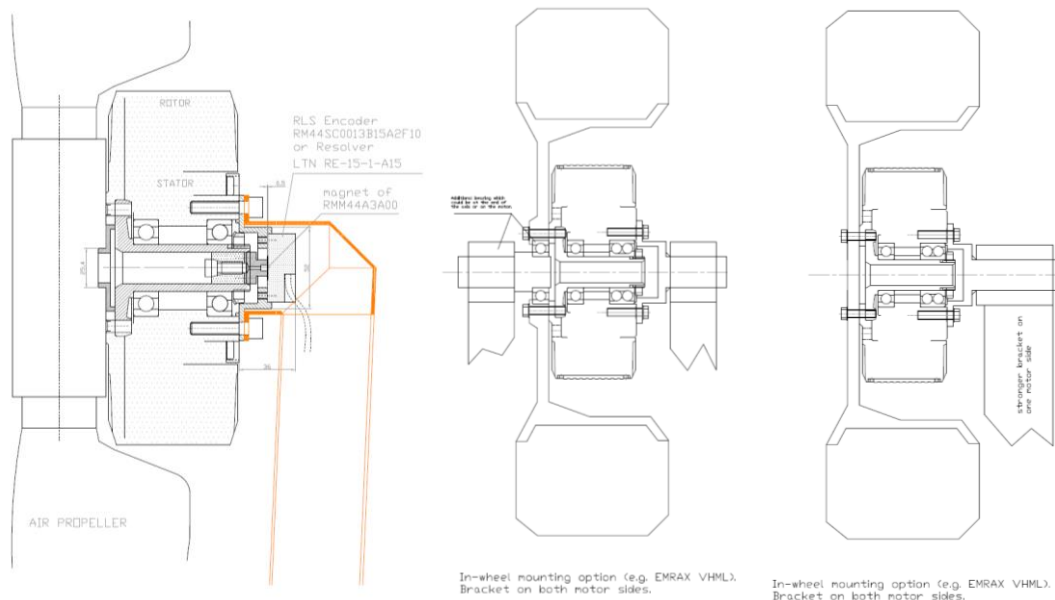

Figure 9: Mounting options (air propeller / in-wheel)

Brackets for mounting EMRAX motors are X shape brackets or they can be custom made. X shape bracket is available for motor size. It is made from stainless steel. Two X shape brackets can be connected together and used for mounting EMRAX TWIN.

7. Power/torque transmission and shafts

Every EMRAX motor has serially included standard shaft. In this case power/torque must be transmitted by using flanged shaft on the front motor side. All shafts for EMRAX motors are hollow. Therefore EMRAX motors have trough-shaft mounting and stacking capability.

The motor power/torque transmission can be made from the front side and/or back side of the motor:

- If the power/torque transmission is from front side of the motor, than the Flanged Shaft with Inner splines (FSI) is needed. It can be ordered from EMRAX company or customer provides it in case custom made splines are needed (inner, outer etc.). Shaft is mounted on the front motor side on six screws (M6/M8/M10 – depends on the motor size).
- If the power/torque transmission is from back side of the motor customer needs Extended motor Shaft with Outer splines (ESO). It can be ordered from EMRAX company. If custom made shaft is needed, customer can provide it. In this case extended motor shaft from back motor side must be sent to EMRAX company before the motor assembly (this shaft has to be made precisely for EMRAX motors according to drawings, that are sent to customer by email). Before sending the shaft customer must contact EMRAX company.

!Note that also if extended shaft from back motor side is used the six screws (M6/M8/M10 – depends on the motor size) must be screwed down into the rotor on the front side of the motor, because they carry the torque from rotor disks to the extended shaft. Screws must be screwed down in the rotor as it is described at Item 6.

!Note also that if power/torque transmission is from back motor side (ESO) hall sensors should be used or encoder / resolver should be mounted to the front motor side by using special bracket, which has to be provided by customer. We can provide drawings. Another option is to use encoder / resolver with bigger hole that can be mounted on the ESO.

- If the motor power/torque transmission is from front and back motor side, than the motor needs flanged shaft with 6 inner splines (FSI) from front motor side and extended motor shaft (ESO) from back motor side. These shafts can be ordered from EMRAX company. If custom made shafts are needed, customer can make provide them – in this case extended motor shaft from back motor side must be send to EMRAX company before the motor assembly (this shaft has to be made precisely for our motors according to drawings that are sent to customer). Before sending the shaft customer must contact EMRAX company.

!Note that if power/torque transmission is from front (FSI) back (ESO) motor side hall sensors should be used or encoder / resolver should be mounted to the front motor side by using special bracket, which has to be provided by customer. We can provide drawings. Another option is to use encoder / resolver with bigger hole that can be mounted on the ESO.

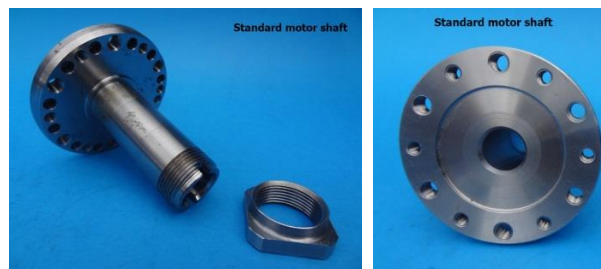

Figure 10: Standard motor shaft



Figure 11: ESO and FSI

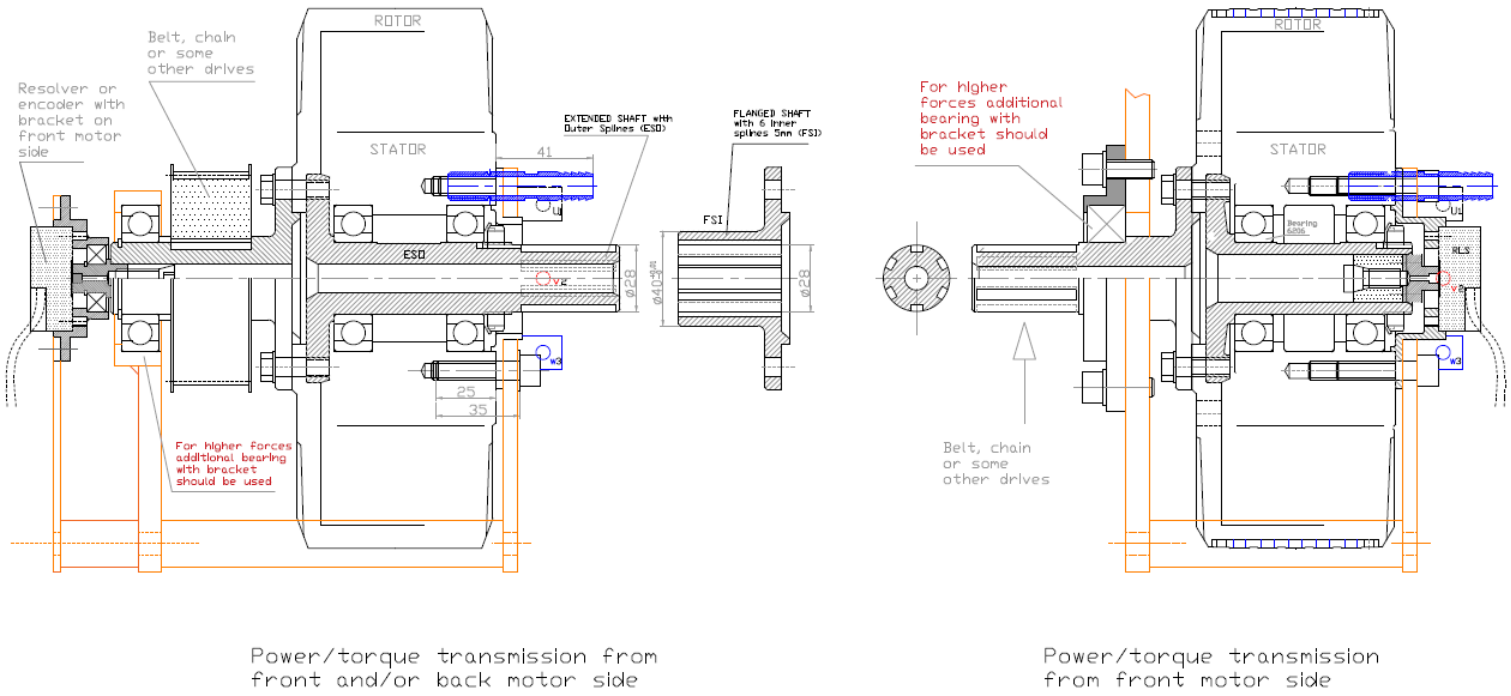

Figure 12: Power/torque transmission from front and/or back motor side

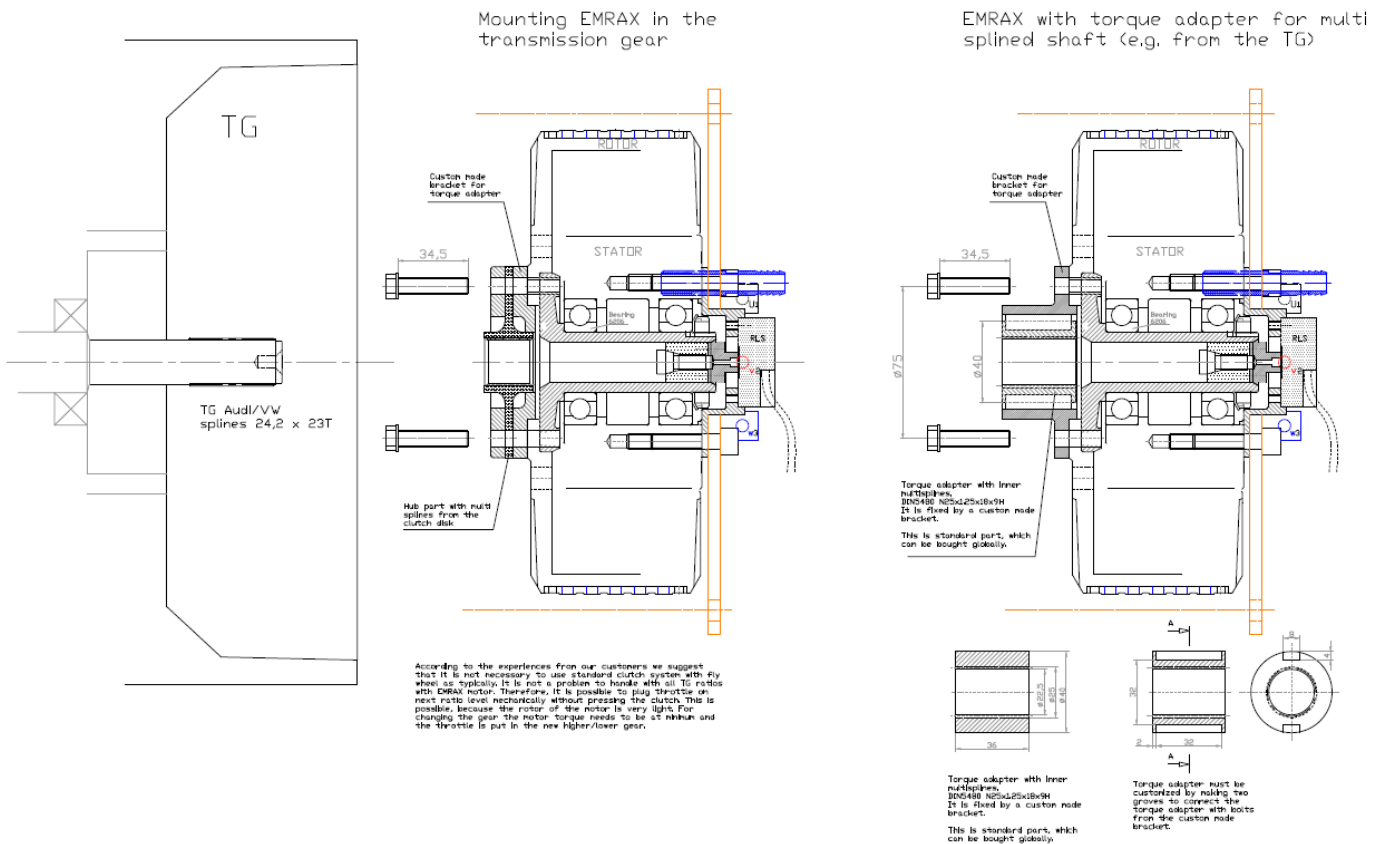
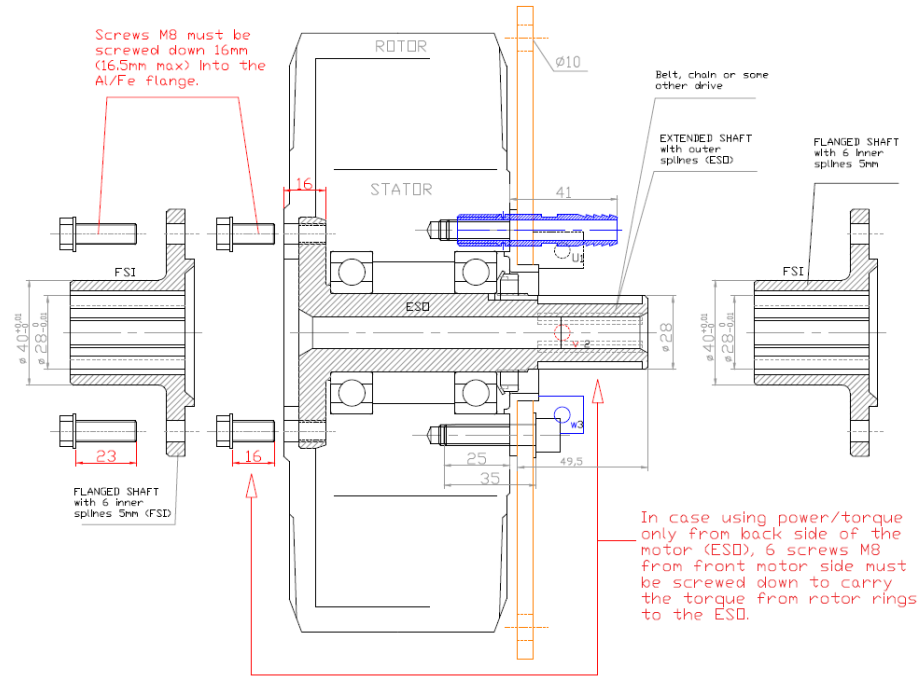

Figure 13: Power/torque transmission from front motor side to the transmission gear



EMRAX with Extended Shaft with Inner splines (ESD) and/or with Flanged Shaft with Inner splines (FSI)

Figure 14: Power/torque transmission from front (FSI) and/or back motor side (ESO)

Extended motor shaft and standard motor shaft cannot be replaced once the motor is assembled.

Our shafts are made from hardened steel (42CrMo4).

If custom made shafts are needed, customer can provide a shaft, which must be made precisely according to EMRAX drawings. Customer can provide motor shaft or extended motor shaft. Shaft dimensions must be discussed with EMRAX company before sending the shaft and mounting it in the motor during assembly. Customer can also make a special flanged shaft for the motor (e.g. with special splines). Another option is to use standard torque adapter (globally available) and mount in on the front side of the motor by using special bracket (Figure 13).

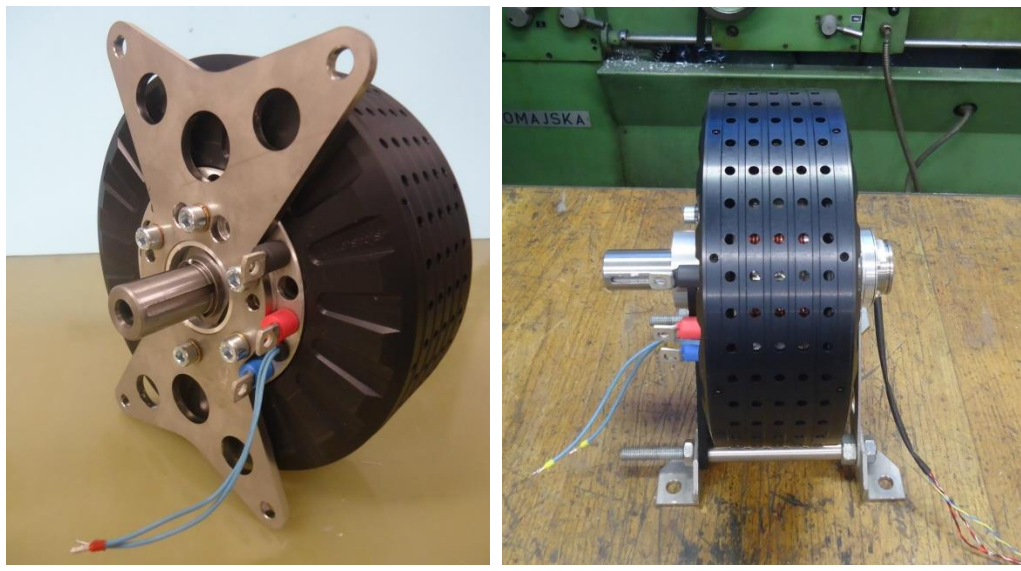

Figure 15: Motor with extended shaft from back motor side

8. Controlling direction, position and rotation speed of EMRAX motors

a) Drive control with sensor:

- For controlling direction, position and rotation speed of the motor sensor should be used. Sensor types that can be used are: resolvers, encoders or hall sensors.
- Sensor must be used for e.g. electric vehicles and propellers that have to stop at the exact position (glider planes, where propeller has to be put into the fuselage).
- Resolver/encoder has to be precisely mounted on the motor by a special bracket. Hall sensors have to be mounted into the motor during assembly of the motor. Sensors with brackets can be ordered from EMRAX company, where they are also mounted. If sensors are not mounted in EMRAX company no warranty applies.

!Note:

- It is important that auto tuning (synchronising electrical and mechanical motor angle) and pre-setting of controller software is done firstly.
- For every motor one sensor (encoder/resolver/hall) is needed if the motor is used with one controller. When one motor is used with two controllers (2 sequences of motor phase connectors – 2xUVW) then two sensors should be used (e.g. tandem resolver). This is when very high motor current has to be ensured.
- For EMRAX TWIN application two sensors (tandem resolver mounted on the second motor) and two controllers are needed. Some controllers (rare controllers) have an option to split the signal from two controllers in only one sensor (usually encoder), which is mounted on the second motor.
- For more information about sensors, please consult with controller producers.

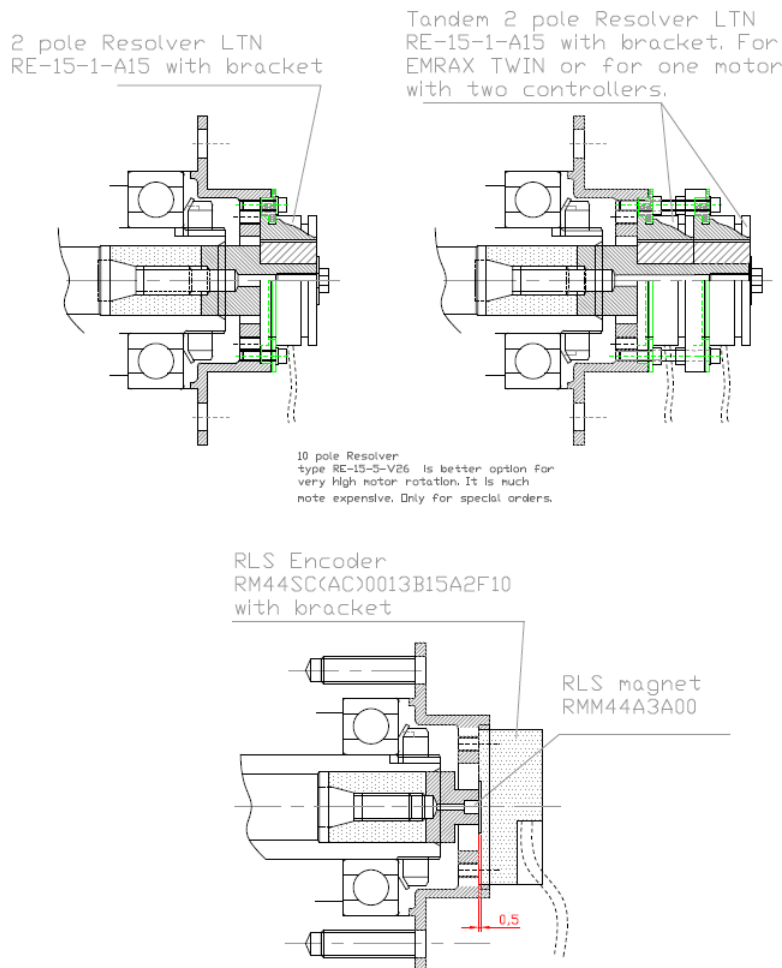

Figure 16: Resolver / encoder on back motor side

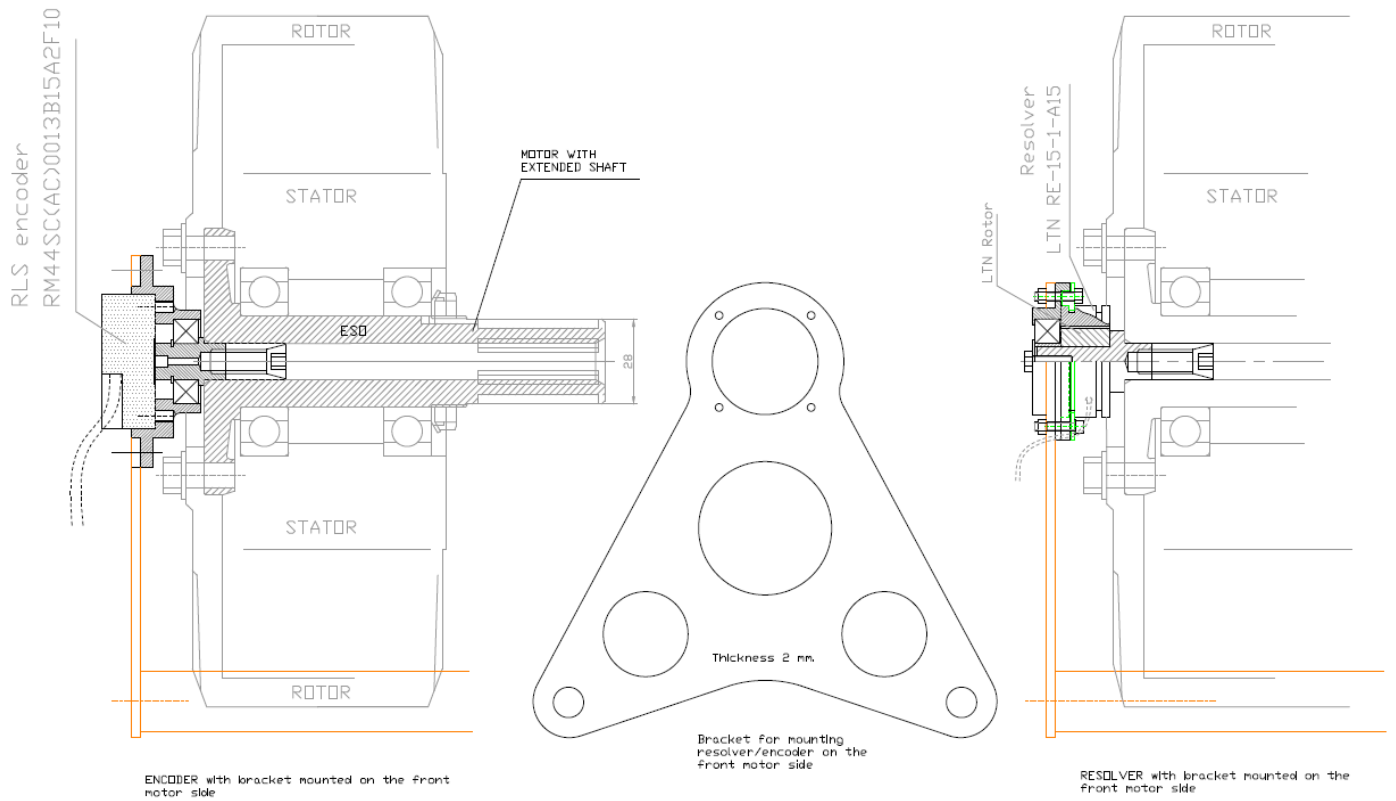

Figure 17: Resolver / encoder on the front motor side

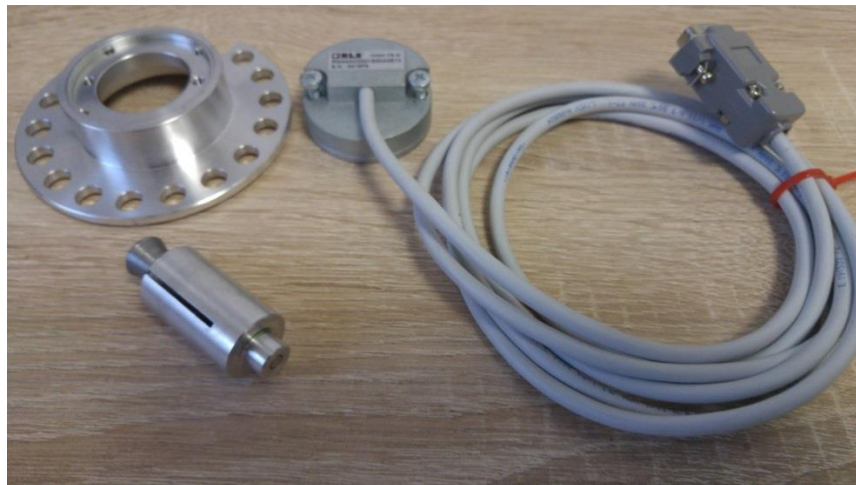

Figure 18: Encoder with bracket

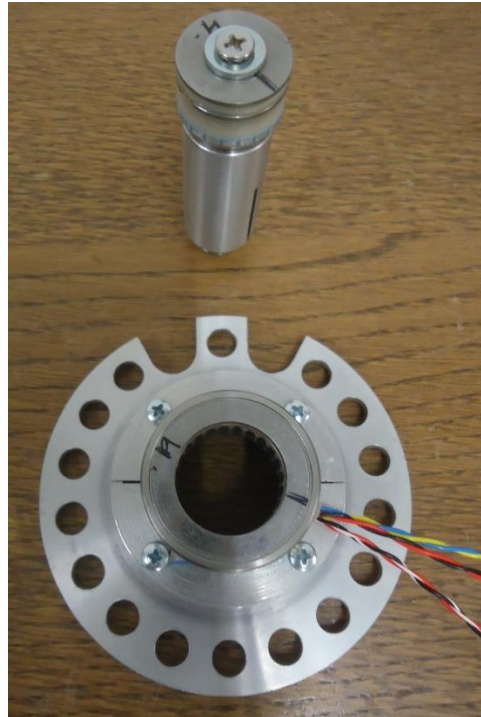

Figure 19: Resolver with bracket

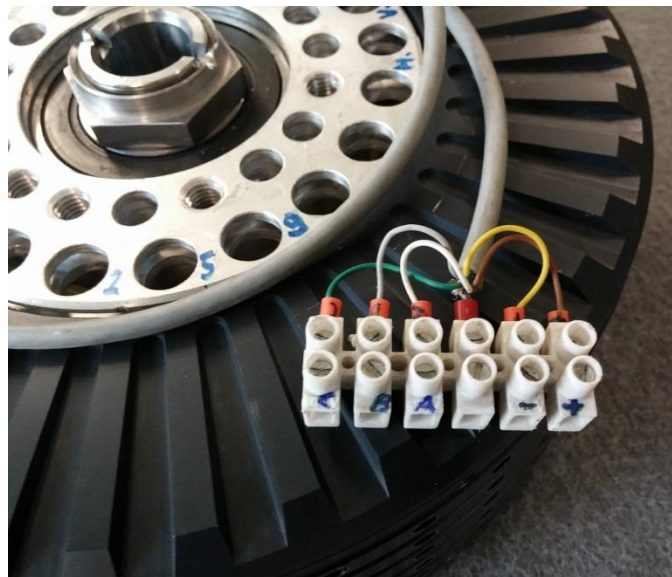
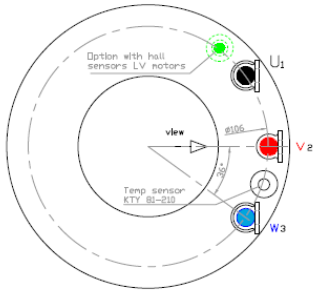
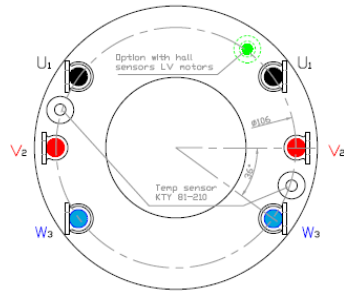
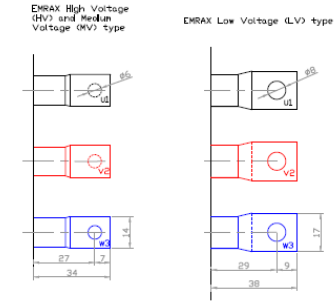

Figure 20: EMRAX with hall sensors

b) Drive control without sensor (sensor-less):

- Direction of motor rotation (clockwise/counter clockwise) can be defined also without a sensor if controller has sensor less option. It can be defined by pole reversal, which can be achieved by a change of two of motor phase cables. Three phase power connectors UVW are shown below on [Figure 21](#). Position and rotation speed cannot be defined without sensor.

- Sensor-less can be used for e.g. boats, airplanes and for applications that don not need high torque at the start (applications with propellers).



Standard phase connectors (UVW), temperature sensor and option with hall sensors (HS).

Doubled phase connectors (2xUVW):

If EMRAX motor is used with two controllers. Especially for low voltage motors to achieve enough high current and in redundancy applications.

It is possible to parallel wire those connectors: U1-U1, V2-V2 and W3-W3 and run the motor like the motor with standard phase connectors (1xUVW).

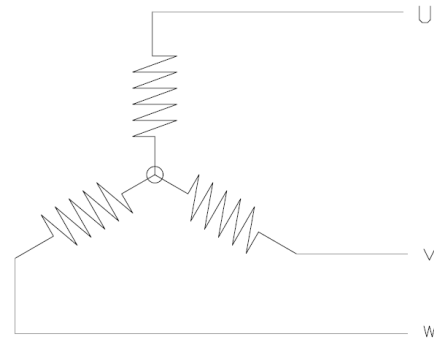

STAR CONNECTION

EMRAX 188, 208, 228, 268 and 348



Figure 21: Motor phase connectors – normal (UVW) and doubled (2xUVW)

9. Suitable controllers for EMRAX motors

Controllers have to be bought directly from the producers. The most suitable controllers for EMRAX motors are from companies:

- Unitek GmbH, Germany
- Emsiso d.o.o., Slovenia
- Sevcon Ltd., United Kingdom
- Reinhart Motion Systems LLC (RMS), USA

Controller has to be selected according to Technical data table of each motor (high motor current and voltage is very important). For some EMRAX motor types it is difficult to find suitable controller even on global market. It is especially difficult to find controller with enough high current, which enables low voltage motors performances listed in the Technical data tables. If the motor current is not high enough, then performances are inferior to the performances in the Technical data tables. For this reason two controllers can be used with one motor, therefore motor can perform with its full performances. In this case the motor windings are wind in two phase sequences (2xUVW). Customer has to order doubled phase connectors sequences on one motor when placing an order.

EMRAX motors should be used with the controllers with **sinusoidal commutation**. If controller with trapezoidal commutation is used, the motor would not work at its best performance, also it would be louder.

Every motor is tested with Unitek Bamocar D3 controller before dispatch. Stator windings are tested at 1500 Vac.

In the table below are listed controllers that are recommended for each motor type (performances of the motor should be calculated according to controller characteristics – current, voltage!):

Motor type	Recommended controller
EMRAX 188 High Voltage	Unitek; Sevcon
EMRAX 188 Medium Voltage	Emsiso emDrive 500 Unitek; Sevcon
EMRAX 188 Low Voltage	Emsiso (2x emDrive 150 or 1x emDrive 500)
EMRAX 208 High Voltage	Unitek (Bamocar D3 400 V) Emsiso (emDrive H300) Sevcon; RMS
EMRAX 208 Medium Voltage	Unitek (Bamocar D3 400 V) Emsiso (emDrive H300) Sevcon; RMS
EMRAX 208 Low Voltage	Emsiso (emDrive 500) Sevcon; RMS
EMRAX 228 High Voltage	Unitek (Bamocar D3 700 V) Sevcon; RMS
EMRAX 228 Medium Voltage	Unitek (Bamocar D3 400 V) Emsiso (emDrive H300) Sevcon; RMS
EMRAX 228 Low Voltage	Emsiso (emDrive 500) Sevcon; RMS
EMRAX 268 High Voltage	Unitek (Bamocar D3 700 V) Emsiso (emDrive H300, for up to 450Vdc - for high torque at lower RPM) Sevcon; RMS
EMRAX 268 Medium Voltage	Unitek (Bamocar D3 700 V) Emsiso (emDrive H300) Sevcon; RMS
EMRAX 268 Low Voltage	Emsiso (emDrive 500 - only up to 130 Vdc → lower RPM → lower power or 2x emDrive H300) Unitek (2x Bamocar D3 400 V) Sevcon, RMS

EMRAX 348 High Voltage	Unitek (2x Bamocar D3 700 V) Sevcon; RMS
EMRAX 348 Medium Voltage	Emsiso (emDrive H300 - only up to 450 Vdc, lower RPM, lower power) Unitek (2x Bamocar D3 700V) Sevcon; RMS
EMRAX 348 Low Voltage	Emsiso (2x emDrive 500 - up to 1200 RPM)

!Note: For the correct type of the controller consult with the controller producer – especially for Sevcon and RMS controllers.

Most controllers use sensors for controlling position, direction and rotation speed of the motor. If the controller has sensor-less option, then sensor is not needed, but in this case only direction of motor rotation can be defined (by changing positions of two phase cables). More information about sensors is written at Item 8.

Recommended sensors for different controllers:

- Most controllers can drive EMRAX motor with encoder, 2 poles resolver or hall sensors. Sensors that are available from EMRAX company are (they are mounted on the motor by special bracket or in the motor):

- **LTN RE15_1_A15** (2 poles resolver) for Unitek Bamocar D3 controller
- **TLTN RE15_1_A15** (2 poles tandem resolver) for two Unitek Bamocar D3 controllers; when using two controllers with one motor (doubled phase connectors - 2xUVW are needed) or for EMRAX TWIN
- **RLS RM44SC** (encoder) for Emsiso emDrive 500 and emDrive H300
- **RLS RM44AC** (encoder) for Sevcon controllers
- **HS SS411P** (three hall sensors; possibility of doubled hall sensors) for Emsiso controllers

- Some controllers (e.g. RMS) require 10 poles resolvers, which are more accurate and can deliver better signal to the controller. Then the controller can deliver better current commutation to the motor. These sensors are especially required for higher speeds. 2 poles resolver can be replaced by 10 poles resolver by using the same resolver bracket. 10 poles resolvers are much more expensive than 2 poles resolvers.

For more information about the suitable sensors, consult with the controller producer.

Every sensor has to be mounted on the motor by special bracket. If the resolver / encoder is bought from EMRAX company it is already precisely mounted on the motor by a special bracket when the customer receives the motor. Hall sensors are mounted in the motor during motor assembly.

!Note:

- Controllers usually can deliver very high peak power and lower continuous power, especially if controller is air cooled.
- Performance of the motor depends also on the controller boost current and voltage (especially peak).
- Batteries should have very high C (Current) rating – very high boost discharging current from the batteries at high motor load.
- For EMRAX TWIN application two sensors (tandem resolver mounted on the second motor) and two controllers are needed. Some controllers (rare controllers) have an option to split the signal from two controllers in only one sensor (usually encoder), which is mounted on the second motor.
- Separated EMRAX motors which are not connected mechanically together (are not on the same shaft), cannot be driven with one controller.

Motor RPM depends on battery DC voltage and magnetic field weakening:

Maximal battery DC voltage delivers maximal motor RPM which should not be exceeded. Take a look at specific load speed in Technical Data Table – RPM/1Vdc. In case using magnetic field weakening option in controller settings the maximal motor RPM can be achieved even at lower DC voltage from the batteries.

Achieving higher RPM with magnetic field weakening (MFW):

Most controllers have an option to set the magnetic field weakening in the controller software program. This setting enables the motor to achieve higher RPM at the same battery voltage. All EMRAX motors can weaken the magnetic field up to 100%. In this case the rotation speed increases, but the power stays at the same level. Torque is lower at higher speed. Efficiency drops only for 1-2 %.

Magnetic field weakening can be set in the controller software. EMRAX motors have 10 pole pairs, therefore it is recommended to weaken the magnetic field 15-20% to achieve the best performances. With higher % of magnetic field weakening the motor

can run faster with very good efficiency, which drops only for 1, 5% at 80% MFW. We recommend MFW only for a short time (few min in case full motor power), because of very high phase current between motor and controller.

!Note:

- Maximal motor RPM should not be exceeded. Maximal motor RPM are listed in Technical data tables for each motor type.
- EMRAX motor has 10 pole pairs, so the motor rotation frequency is very high, especially at higher motor speed. Therefore controller for EMRAX motor has to be made for high rotation frequencies.

For example: at 6000 RPM the rotation frequency is 1000 HZ. So controller must deliver stable and smooth signal even at high rotation frequency with high PWM. $RPM = 60 * Hz / PP$.

10. Two same sized EMRAX motors connected serially (EMRAX TWIN) – stacking capability of EMRAX motors

Two same sized EMRAX motors can be connected serially – this is EMRAX TWIN. All EMRAX motor types can be connected into TWIN.

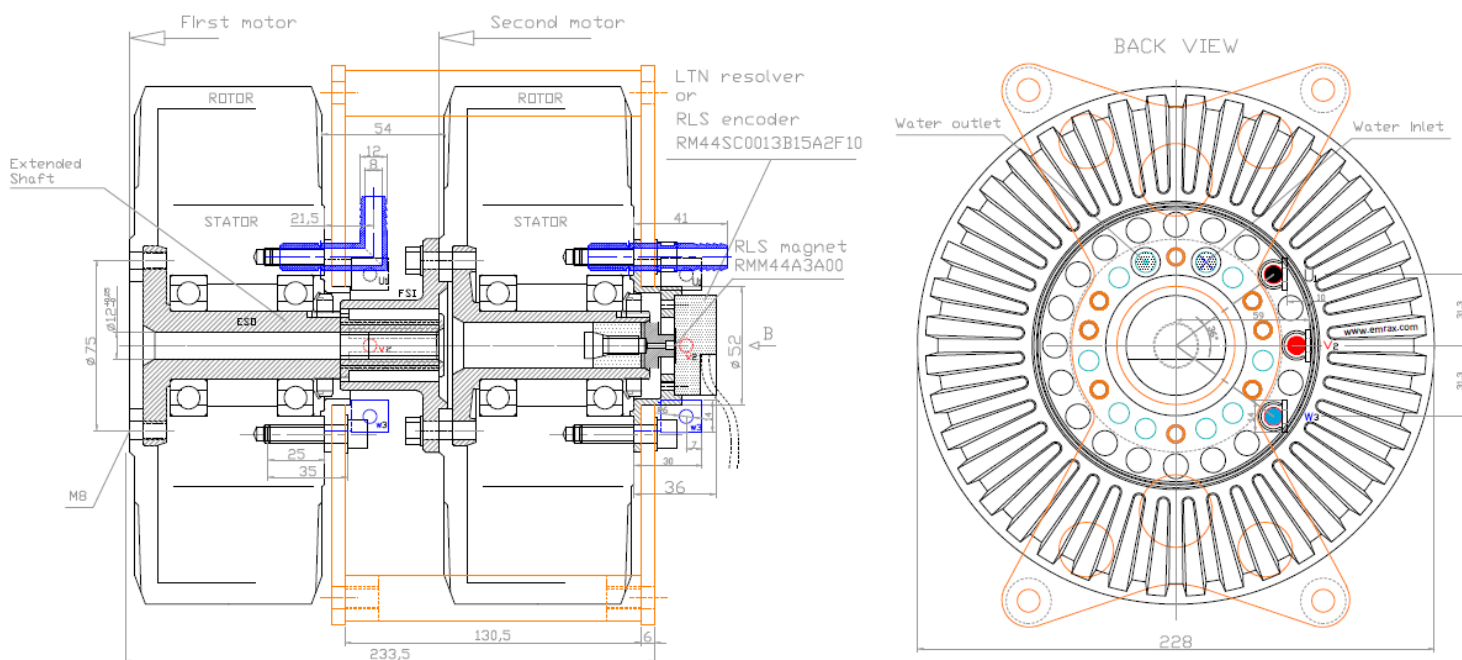

EMRAX TWIN (e.g. size 228) – two same sized wired serial (stacking capability of EMRAX motors)

The first motor has Extended Shaft with Outer splines (ESD). This shaft is connected to Flanged Shaft with Inner splines (FSI), which is connected to the second motor. At the front side of the first motor customer can add another FSI for sprocket or some custom made drive option. EMRAX TWIN needs two special original iron brackets (X-shape).

Figure 22: EMRAX TWIN drawing

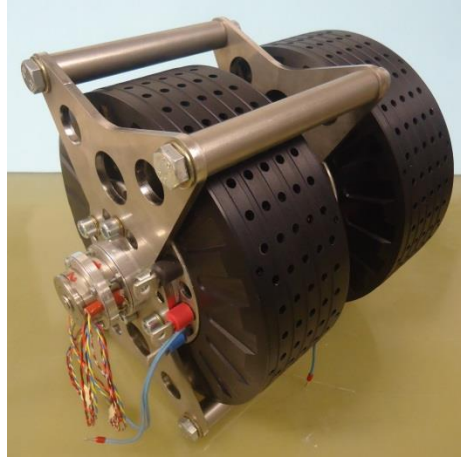

Figure 23: EMRAX TWIN picture

Parts for EMRAX TWIN:

- First motor needs Extended shaft with outer splines (ESO)
- Second motor needs Flanged shaft with inner splines (FSI)
- 2 pcs of X shape bracket made from stainless steel
- If direction, position and rotation speed of the motor need to be controlled sensors are needed (more information at Item 8). Sensors that can be used are: tandem resolver (two resolvers wired serially – recommended), one encoder if the controller has an option to split the signal (rare controllers) or hall sensors in every motor. For more information about sensors, please consult with controller producers.

The first motor is connected to the second motor by using ESO shaft, FSI shaft and two X shape brackets. ESO and FSI shaft must be made by EMRAX company, otherwise the warranty does not apply.



Figure 24: EMRAX TWIN shafts – ESO is mounted in the first motor and FSI on the front side of the second motor

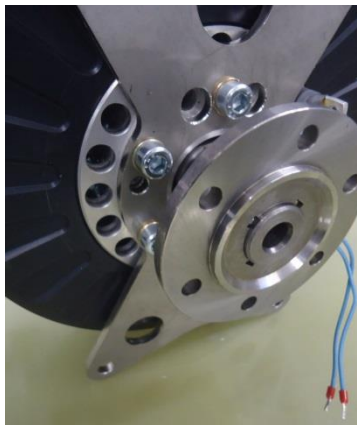

Figure 25: Motor with extended shaft and flanged shaft on the extended shaft (for EMRAX TWIN)

11. Redundancy

2 options:

- EMRAX TWIN, which needs to be driven with two controllers and needs tandem resolver (TLTN) or hall sensors in every motor. In case one controller/motor failure the others are still working.
 - One EMRAX motor can be driven with two controllers. In this case EMRAX motor needs doubled phase connectors (2xUVW). In case of one controller failure, the other still drives the motor (performances are lower). Sensors: tandem resolver (TLTN) encoder if controller can split the signal or doubled hall sensors.
- Redundancy may be considered for airplane applications.

12. EMRAX motor working as a generator and its integration into hybrid system

EMRAX motors can be used as generators for electricity production. The same performance characteristics can be achieved in the motor and generator modes of operation. Technical data and graphs for the generator application are the same as for the motor application if the generator is driven by the controller. In case generator is driven without controller the power / torque is approximately 50% lower, because there is no control of the correct electrical-mechanical angle at load. Also additional controller for converting generator three phase alternating signal to grid signal (230V/50Hz) is needed.

EMRAX motor can be used in a hybrid propulsion system as generator, which generates energy and charge the batteries in regeneration mode by using controller and battery management system (BMS). Controller and BMS at the same time drive diesel engine on the right power/RPM for charging the batteries at optimal level. In the end of charging they also balance the battery cells and turn off the diesel engine. Emsiso emDrive controllers and BMS system from REC company, Slovenia can do this.

13. EMRAX motor ingress protection (IP CODE)

- **IP21:**
 - a) Air Cooled (AC): only air cooled
 - b) Combined Cooled (CC): air and liquid cooled (water/glycol mixture)
- **IP65:**
Liquid cooled (LC): Totally closed motor. Dimensions and weight of this motor are the same as for EMRAX with IP21. Continuous power / torque are up to 20% lower, peak is the same compared to EMRAX with IP21.

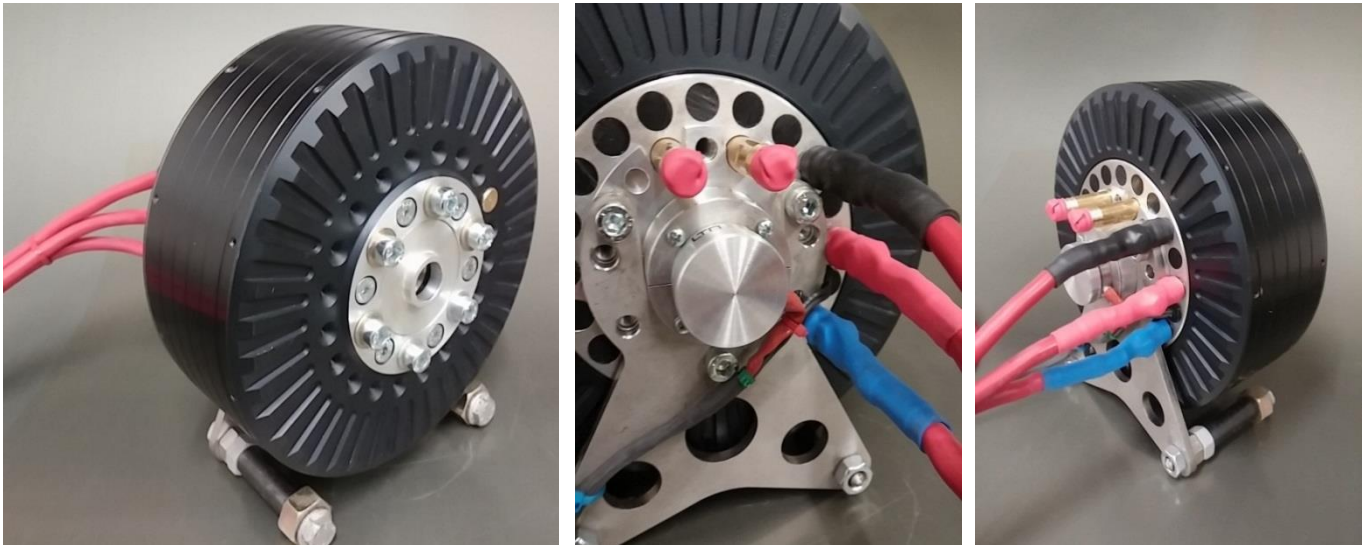

Figure 26: EMRAX IP65

14. Motor cooling

It is important to care for a sufficient cooling of the motor at any time. In every case, the temperature sensor that is mounted in the controller must be connected to the controller. This sensor protects the motor from overload. In case temperature is too high and not stable controller drives the motor with lower current until the temperature becomes stable under the limit. Standard temperature sensor that is mounted into the motor is KTY 81-210. Other type can be mounted (e.g. PT1000) if customer upfront consults with EMRAX company. EMRAX motors can be air cooled (IP21), liquid cooled (IP65) or combined cooled (IP21).

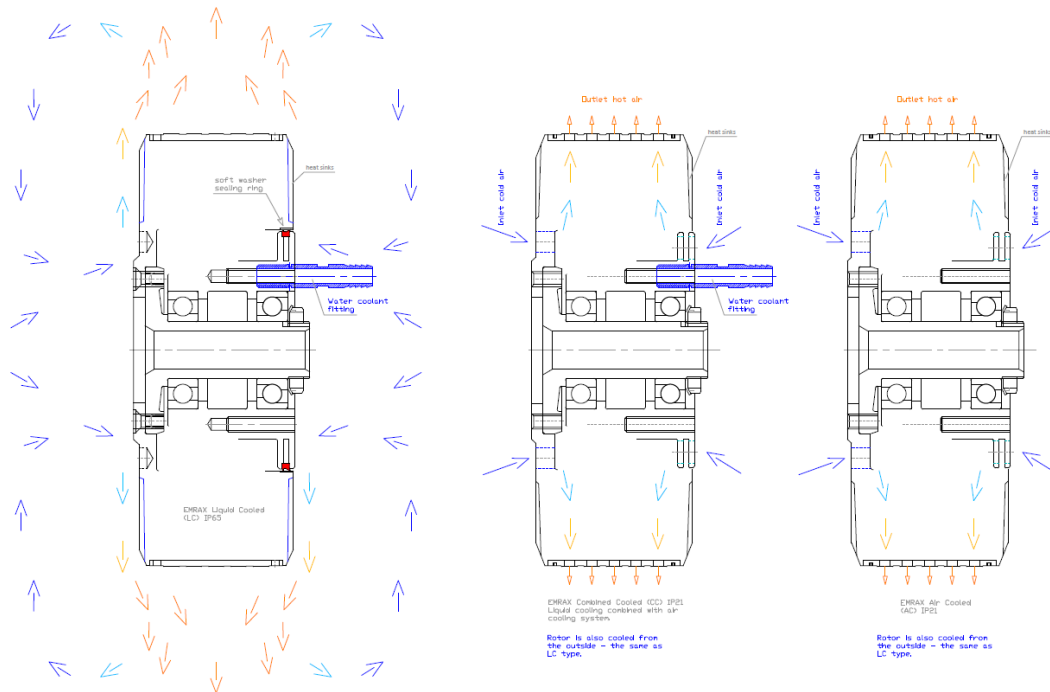

Figure 27: Motor cooling options

EMRAX motors have to be used under ambient and motor cooling conditions, which are described in Technical data tables. Failure to comply with these conditions causes a forfeit of warranty claims.

- The EMRAX motor **must not exceed the temperature below -30°C and above 120°C on copper windings and on the magnets. These values are also valid for the bearings.** If the temperature exceeds these values, it causes a forfeit of warranty claims. Indicator for exceeded temperature is placed in the motor. In case of disconnection of the temperature sensor, which has to be on the copper windings, the controller has to stop the motor. The motor temperature sensor detector in the controller must always be enabled, during the motor operation. **The temperature sensor in the motor only measures the temperature of the stator, not the temperature of the magnets, so the magnets temperature (outer/surface temperature of the motor) has to be measured with thermal camera.** It must be considered that the surface temperature is lower compared to magnet temperature – difference is approximately 10-20 °C (depends on the load).
- **IP21 motor:**
 - **EMRAX Air Cooled AC (air cooled):**
Fresh air has to be served to the drive symmetrically and sufficiently. Air speed must be **20 m/s at maximal 25°C air temperature and at maximal 200 kPa pressure.** This has to be ensured by intake ports or other air conduction measures. Motor can be protected with some net against the dirt.
 - **EMRAX Combined Cooled CC (air and liquid cooled):**
Liquid cooling flow must be **6 to 8 litres per minute at maximal 50 °C inlet water/glycol temperature and ambient air temperature has to be 25°C or less.** Inlet water/glycol temperature and ambient temperature can also be lower – in this case the continuous motor power is higher. This is valid for all EMRAX motor sizes.

To achieve good inlet water/glycol flow rate which is recommended (from 6 to 8 l/min) the inlet pressure for the different motor types must be:

Motor size	Water/glycol flow pressure (pressure drop)	Water/glycol flow rate
188 CC	0,5 bar	7 l/min
208 CC	0,6 bar	7 l/min
228 CC	0,9 bar	7 l/min
268 CC	1,0 bar	6 l/min
348 CC	1,0 bar	6 l/min

!Note:

- Maximum inlet water/glycol flow pressure must not exceed 2 bars.
- Inlet water/glycol flow pressures are valid if the tube length between the motor coolant fittings and the pump is up to 2 meters (diameter is 12 mm). If the tube is longer higher pressure in accordance with the pressure drop must be used.
- For combined cooled motor it is important that beside liquid cooling also air cooling is assured – this means that the air around the motor must be exchanged (air circulation) and that the ambient air temperature must be 25°C or less (as described in Technical data tables) to get the best performances of the motor.
- The motor must not be closed into some box without possibility of exchanging the air. Liquid cooling is important for the stator, air cooling is important for the rotor. Motor can be protected with some net against the dirt.
- Liquid flow must be filtered cross the filter which openings diameter or diagonal must not exceed 2 mm.
- We recommend original coolant fittings, which have special O sealing ring. If the tubes are sealed with some other sealing material, we do not guarantee that system is waterproof.
- We do not recommend cooling the motor with salt water, because long-term exposure of motor cooling system might lead to mineral deposits. Therefore we recommend heat exchanger. Motors were not tested in salt environment and cooled with salt water.

• **IP65 motor:**

○ **EMRAX Liquid Cooled LC (liquid cooled):**

This motor is totally closed. Liquid cooling flow must be **6 to 8 litres per minute at maximal 50 °C inlet water/glycol temperature and ambient air temperature has to be 25°C or less**. Inlet water/glycol temperature and ambient temperature can also be lower – in this case the continuous motor power is higher. This is valid for all EMRAX motor sizes.

To achieve good inlet water/glycol flow rate that is recommended (from 6 to 8 l/min) the inlet pressure for the different motor types must be:

Motor size	Water/glycol flow pressure (pressure drop)	Water/glycol flow rate
188 LC	0,5 bar	7 l/min
208 LC	0,6 bar	7 l/min
228 LC	0,9 bar	7 l/min
268 LC	1,0 bar	6l/min
348 LC	1,0 bar	6 l/min

!Note:

- Maximum inlet water/glycol flow pressure must not exceed 2 bars.
- Inlet water flow pressures are valid if the tube length between the motor coolant fittings and the pump is up to 2 meters (diameter is 12 mm). If the tube is longer higher pressure in accordance with the pressure drop must be used.
- Even though the motor is liquid cooled only the ambient temperature is an important factor for achieving high constant power. The ambient temperature must be 25°C or less (as described in Technical data tables).
- The motor must not be closed into some box without possibility of exchanging the air.
- Liquid flow must be filtered cross the filter which openings diameter or diagonal must not exceed 2 mm.
- We recommend original coolant fittings, which have special O sealing ring. If the tubes are sealed with some

other sealing material, we do not guarantee that system is waterproof.

- We do not recommend cooling the motor with salt water, because long-term exposure of motor cooling system might lead to mineral deposits. Therefore we recommend heat exchanger. Motors were not tested in salt environment and cooled with salt water.

15. EMRAX motor materials, quality and reliability

EMRAX motors are quality made and consist of quality advanced materials. Materials are able to withstand extremely high power / torque (high temperature resistant, shatterproof, stiff) and are corrosion resistant.

Stator part, outer ring, front and rear disk are made of aluminium quality 6082. Minimum aluminium thickness is 3.0 mm which is on the outer ring. Outer ring, front and rear aluminium disk are anodized in black.

Even though rotors with magnets represent approximately 40% of the motor weight, direction of motor rotation can be changed in a fraction of second. This is possible due to very quality motor shaft, which is made from hardened steel (42CrMo4) and quality bearings, which are chosen for long time duration.

Stator with copper windings has additional epoxy coating.

Magnets have UH grade 180°, which means that are resistant to up to 180°C. They are excellent chemically and mechanically fixed, therefore EMRAX motors are very reliable. EMRAX motors are sold to airplane industry where reliability is extremely important. Due to adequate fixation of the magnets and quality advanced materials and motor design, EMRAX motors can be rotated even up to 8000 RPM (EMRAX 188 and 208 types).

The generator voltage of EMRAX may vary for 1-2% at the same rotation speed. This is due to the difference of the magnetic field of the magnets (tolerance 1-2%). The difference in voltage also depends on the other materials of the motor.

16. EMRAX motor bearings and life expectancy

Bearings of the rotor are not qualified for forces higher than bearings included in EMRAX motors can transfer. Bearings that are used are FAG or SKF models, which are listed in Technical data tables for every EMRAX type and at Item 3. All technical information about listed bearings is publicly available.

Every EMRAX motor includes two bearings – front and back. Distance between the front and back bearing can be measured from drawings. Bearing type depends on the load (direction and amplitude of the force applied on the motor shaft).

Bearings for EMRAX motors are listed at Item 3 in the tree structure. Bearing types that are described are used for most applications. If special bearings are needed (e.g. for in-wheel application), customer must consult with EMRAX technical support before placing an order. Bearings are mounted in the motor during motor assembly. The bearing type must be calculated and selected by customer.

To choose correct bearing, the calculator on the link below must be used. Size of the bearing must be correct (according to EMRAX motor drawings). We offer FAG and SKF bearings.

To check if the bearing is suitable for forces applied on the shaft you can use publicly available **FAG bearing calculator**:

http://medias.ina.de/medias/en!hp.ec/1_R*0*C

1. Firstly enter type of the bearing in the box on the right side (e.g. 6206).
2. New window opens with search results. Choose the product (e.g. 6206-2z, which means that it is closed from front and back side).
3. Now you can choose *Calculation* tab.
4. Double click on *Loadcase 1* on the right side of the window.
5. In the window that opens enter the magnitude of axial force (F_a), magnitude of radial force (F_r), rotation speed and operating temperature. Click on the calculator icon in the top row (5th icon from the left). Under the picture of bearing you will see rating life in hours.

Life expectancy of EMRAX motor is the same as life expectancy of the bearings that are mounted in the motor. If bearings are overloaded than bearing life time is shorter. They can be replaced.

In case of doubts, the case of operation shall be discussed with the manufacturer of the bearings or EMRAX company. If the radial or axial load is higher than bearings can bear, than the system must have additional shaft with stronger bearings (belt transmission, chain transmission, gear transmission, direct drive applications). EMRAX company can insert some customized bearings combinations (e.g. with tapered rolling bearings with additional sealing rings). This has to be discussed by EMRAX company upfront.

A static redundant dimensioning caused by the thrust bearing must be avoided in any case. Certain resilience in the mount of the drive or the thrust bearing is satisfactory. Required is a clean rotation of the extension shaft. The shaft must be able to be rotated smooth and easy by hand after mounting.

Tapered bearings must be lubricated according the bearings lubrication instructions from bearing producer.

Bearings are mounted in the motor during assembly. They can be replaced only at EMRAX company. Any opening and/or bearing replacement not done by EMRAX company causes forfeit of warranty claims! Also opening EMRAX motor can cause health damage. Therefore please avoid opening the motor.

17. EMRAX motors as in-wheel motors

All EMRAX motor types can be used as in-wheel motors. Important considerations before placing an order are:

- Bearings selection according to forces applied on the shaft (torque, weight of the vehicle) – more information about bearings at Item 16.
- Motor shaft selection according to forces applied on the shaft (torque, weight of the vehicle) – more information at Item 7.

EMRAX motor for in-wheel application must be totally closed (IP65; Liquid cooled).

For most in-wheel applications EMRAX 268 VHML is appropriate. Anyway forces that will apply on the shaft and bearings should be discussed before placing an order.

In-wheel mounting options for EMRAX can be seen on **Figure 9** at Item 6.

18. Maintenance and protection of EMRAX motor against environmental disturbances

- The drive does not need any maintenance during life time. Life time of EMRAX motors is the same as the lifetime of the bearings that are included in each motor.
- However it has to be considered that no foreign objects at all can enter the interior of the drive. This is especially important for EMRAX motors with IP21 (Air Cooled and Combined Cooled). Further, it is necessary to protect the motor from humidity, dirt, paint, glues, salt, iron particles, etc. If this is ignored, a proper functionality of the motor cannot be guaranteed and irreparable damages are possible. To prevent objects falling inside the motor (especially iron chips, iron fillings), **the motor ventilation holes (ring and side holes) MUST be protected with some tape for the time the motor is being assembled into the system and at the time when the drive is not in use. The drive must be protected from these objects even when it is already mounted in the system (especially if the motors are mounted close to the ground and if there are iron particles). In this case the motor should be protected with some fine net, so that cooling stays sufficient at the same time!** Anyway if the foreign object enters the motor do not at all simply keep on using the drive! In this case contact EMRAX company and explain what happened. Unintended handling leads to secondary damages. **Opening or disassembling of the motor causes a forfeit of warranty claims!** Also for opening the motor special tools are needed to prevent any damages to the motor and to the person who opens the motor. Opening of the motor must be avoided in any case. EMRAX company can remove the foreign object from the motor and at the same time also checks the interior of the motor and protect it again. Removing particles from the motor, inspection and protection of the stator costs approximately 190 euros per motor. Customer also has to pay shipping costs and duty costs that may be incurred.

- In case of damage, ship the drive back to EMRAX company for repairs. It is important, that you contact EMRAX company before sending the motor back.
- Keep magnetic memory cards or electronic devices out of the rotor's close-up range, because the alternating magnetic field can cause a delete of data. Be careful with medical devices (e.g. pacemakers) which are sensitive to alternating magnetic fields.

19. Starting EMRAX motor (connecting the motor with controller):

1. Firstly it is important to read the manuals for the EMRAX motors and for the controllers!
2. Be aware of the following safety instructions before starting:
 - It is essential to permanently check the loads driven by the motor for damages, cracks etc. The use of damaged loads can lead to heaviest injuries.
 - The frequency converter needs to be mounted jacked up, so that a vibration free use is unconditionally guaranteed. If this is not the case, vibrations can cause contact faults and further the breakdown of devices. This may lead to damages to the electronic system or to components in its environment.
3. **Connecting EMRAX motor, controller and batteries:**
 - Before starting, the right direction of rotation has to be checked and if necessary changed – motor connectors UVW must be set according to the controller phase positions. UVW (1, 2, and 3) connectors of the motor are parallel to UVW output phases from the controller. If sensor (encoder / resolver / hall) is used it has to be properly connected to the controller. Instructions can be provided by sensor producer or controller producer. For connecting instructions of RLS encoder / LTN resolver / hall sensors please contact EMRAX company. The drive should be if possible directly connected to the frequency controller, without any inserted connectors. If this is not possible, only use high current capable, low-impedance, the best quality connectors. Shoddy connectors lead to voltage peaks and can destroy the frequency converter. Oftentimes unplugging the connector can cause contact problems which may also lead to a destruction of the converter. We also recommend main vacuum switch between the batteries and controller and suitable DC fuse.

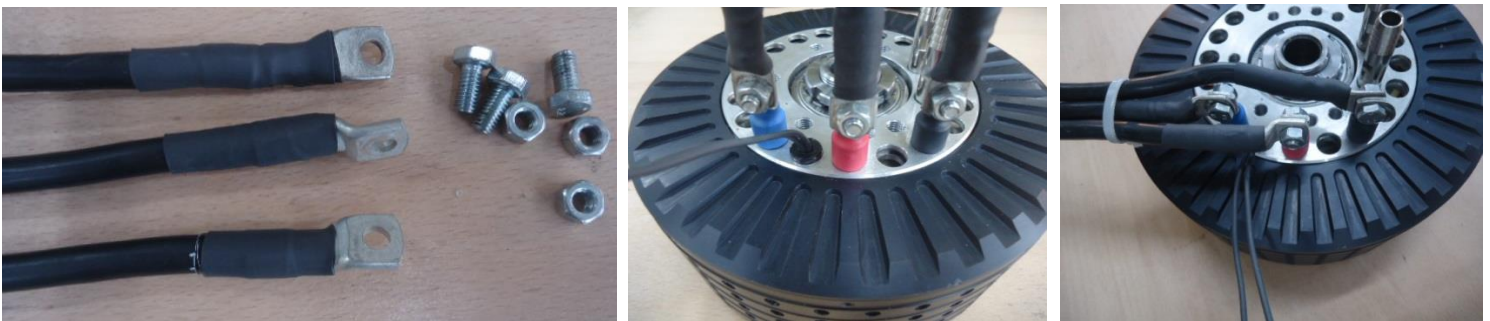

Figure 28: Straight connection of motor phase connectors to controller cables.





Figure 29: Angular connection of motor connectors to controller cables. Connections must be isolated with shrink hose!

- Only use high current connector systems between the motor, converter and the battery. The connectors have to be checked before every use. If the coating is used up, the internal discs in the jacks get play or have lost their resilience, they have to be replaced.
- Shoddy or used up connectors are the most common reason for destructions of the drive, the controller and possible components around it.
- **The electric connectors and cables must be connected professionally and have to be isolated with a shrink hose.**

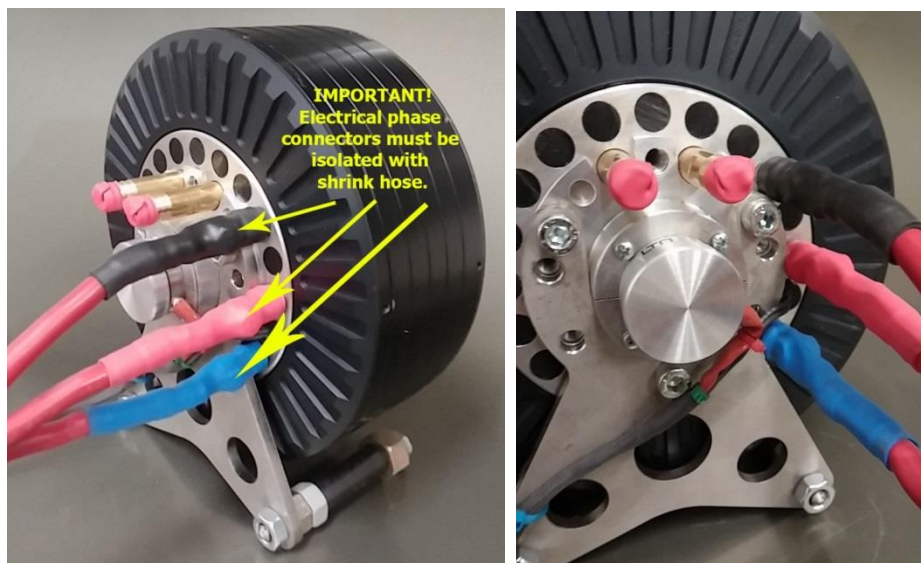

Figure 30: Isolation of electrical phase connectors with shrink hose

- Mixing up the polarity of the battery or a short circuit leads to a destruction of the drive and means an acute fire hazard and danger of life!
 - The cables should be as shorter as possible. For longer cables diameter of the cable must be bigger. **Power cables must be shielded and distant enough from communication cables.**
- 4. Setting the controller software:**
- Basic controller software settings must be set in the controller software. Basic controller settings are published on our web site: [link](#). These files are for Unitek controller. Other controllers are using similar parameters, which can be set by using these parameters and Technical data table of the motor.
 - Afterwards auto-tuning must be made. This means automatic adjustment of electrical angle according to mechanical rotor position. This is a very important step for proper operation of the engine! When auto-tuning starts the motor slowly rotates for 360 mechanical degrees. Every controller has different system for automatic adjustment of electrical angle, so make sure you read the manual of the controller or consult with the controller producer.

- Now you can start the motor and adjust software parameters according to your application. Be sure you enter the parameters that are in accordance with Technical data table! Otherwise it causes forfeit of warranty claims.

20. How to choose the correct EMRAX motor type for every application:

1. First you need to know RPM and torque that you will need for your application. You have to make sure, that desired RPM and torque (without transmission gear) do not exceed maximal RPM and torque listed in Technical Data Table for specific EMRAX motor. You also need to make sure, to consider Torque/RPM graph! Torque also depends on controller current to the motor, therefore the controller needs to have enough high phase current to get enough high torque.
2. In Technical Data Table you can find Specific load speed (RPM/1Vdc). With this data you can calculate how many RPM you will get at desired battery voltage (Vdc) at load application.
*It is possible to achieve higher RPM with magnetic field weakening (MFW). You can use magnetic field weakening when torque is at maximal value. At magnetic field weakening torque goes slightly down, but RPM rise and consequently power stays the same (take a look at the equation below). Magnetic field weakening can be set in the controller software. EMRAX motors have 10 pole pairs, therefore it is recommended to weaken the magnetic field 15-20% to achieve the best performances. With higher % of magnetic field weakening the motor can run faster with very good efficiency, which drops only for 1, 5% at 80% MFW. We recommend MFW only for a short time (few min in case full motor power), because of very high phase current between motor and controller.
3. Now you can calculate power, using this equation:

$$P [kW] = n [RPM] * Mt [Nm] / 9550$$

At lower RPM (motor rotation), you can expect lower motor power at the same torque. At higher motor speed you can expect higher motor power at the same torque.

Mt.....torque [Nm]

P.....power [kW]

n.....motor rotation [RPM]

In case you need higher power we recommend you to increase battery voltage (Vdc) instead of increasing motor current – because cables with bigger diameter are needed and consequently weight is bigger. It is better to use High Voltage motor if you need higher speed (RPM).

4. Example for 228 MV:

Customer has battery voltage 365 Vdc at load.

228 MV motor can deliver 11 to 14 RPM per 1 Vdc at no load. At full load it can deliver 11 RPM/1Vdc.

This means that you can get $365 [Vdc] * 11 = 4015 [RPM]$ only.

Therefore at 180 Arms peak from controller from Bamocar D3, the motor power is:

$4015 [RPM] * 180 Nm \div 9550 = 75 [kW]$ This is maximal what you can expect with this controller. If you want more power you need higher dc voltage to get higher RPM and also higher motor current. You need app 280 Arms peak (which gives app 230 to 240 Nm of torque). So if you can increase the current you will be closer to 100 kW. But we recommended that you increase the battery voltage to get higher RPM and consequently higher power.

21. Usage of EMRAX motors for electric vehicles (EV)

How to calculate power and torque for EV?

1. First you have to calculate the torque that will be needed for the vehicle (torque on the wheels):

Example:

EV weight:	G = 1700 kg
Acceleration time from 0 km to 100 km/h (= 27,78 m/s):	t = 5 sec

Acceleration:

$$a = v \div t = 27,778 \text{ m/s} \div 5 \text{ s} = 5,55 \text{ m/s}^2$$

Force for acceleration:

$$F = 1700 \text{ kg} * 5,55 \text{ m/s}^2 = 9444,5 \text{ N}$$

Torque on the wheels (wheel diameter 0,64 m):

$$Mt = 9444,5 \text{ N} * 0,32 \text{ m} = 3022,2 \text{ Nm}$$

3000 Nm is a torque on the wheels, which is needed to accelerate the vehicle (EV weight is 1700 kg) from 0 km/h to 100km/h.

2. Now you need to consider the transmission gear (TG) ratio and calculate the torque:

Example:

Differential ratio is approximately 3:1, TG ratio is approximately 4:1. Therefore total ratio in the first gear is:

$$\text{total ratio} = 3 * 4 = 12$$

For example, one EMRAX 228 motor can deliver 240 Nm peak torque and 120 Nm continuous torque. Therefore peak torque on the wheels in first gear is:

$$\text{total peak torque on the wheels in first gear} = 12 * 240 \text{ Nm} = 2880 \text{ Nm}$$

In this case close to 3000 Nm of peak torque in first gear can be expected. In the second gear the torque is lower. Only higher gear can deliver higher and finally end speed of EV.

End speed also depends on the maximal battery voltage (Vdc) and magnetic field weakening (MFW) – more information at Item 9. Final EV speed can be even higher if magnetic field of the motor is

weakened. This can be done in the controller settings. Power stays the same at higher speed. Power of EV is rising at higher speed because of air drag.

EV needs enough high torque for starting EV and driving up the hill. 15% slope is minimal for torque calculation.

3. Torque, power calculation:

$$P [kW] = n [RPM] * Mt [Nm] / 9550$$

At lower RPM (motor rotation), you can expect lower motor power at the same torque. At higher motor speed you can expect higher motor power at the same torque.

Mt.....torque [Nm]

P.....power [kW]

n.....motor rotation [RPM]

Very important considerations when calculation power and torque for EV:

- acceleration
- air drag at higher speed
- driving up the hill

Usually there is no need to add higher torque for climbing up the hill, because it is enough high torque in the first gear in case using TG. Only EV speed is lower. Normally we do not need to drive up the hill at full speed.

EV must start with good acceleration even at very low RPM or at zero speed. Therefore the most important is motor torque and reduction drive ratio (belt drive, chain drive, differential or transmission gear etc.).

Mounting options of EMRAX motor for electric car:

- In-wheel (Figure 9 at Item 6)
- On the differential
- In the transmission gear (TG).

Firstly you should know how high torque you need on the driven wheels.

- 1.) If you use the transmission gear then one EMRAX 208 gives enough power:
1900 Nm peak / 900 Nm continuous in the first gear.
- 2.) EMRAX 228 mounted in the TG is better option. You can expect much better EV acceleration, also you will be able to drive up the hill at higher gear:
3800 Nm peak / 1900 Nm continuous in the first gear .
- 3.) EMRAX 228 is useable for lighter EV if mounted directly on the differential:
nearly 1000 Nm peak / 500 Nm continuous on the wheels at full range of motor RPM.
- 4.) EMRAX 268 is useable for heavier vehicles if mounted directly on the differential:
approximately 1600 Nm peak / 800 Nm continuous on the wheels at full range of motor RPM.
- 5.) If EMRAX 268 is mounted in the TG, than you can expect very high torque:
6000 Nm peak / 3000 Nm continuous on the wheels at full range of motor RPM.

You can also use EMRAX TWIN (torque/power is doubled). Peak torque means that the power lasts 1-2 minutes.

Example of calculation for electric Audi ETT:

Engine:	1x EMRAX 268 MV CC(IP21)
Differential gear ratio:	$i = 2,65$ (BMW differential)
EV weight:	$G = 1500$ kg
Peak / continuous motor torque:	500 Nm / 250 Nm
Wheel diameter:	$D = 0,64$ m
Battery capacity:	$Q_{bat} = 30$ kWh

Acceleration:

Maximal torque on the front wheels:

$$M_w = 500 \text{ Nm} * 2,65 = 1325 \text{ Nm}$$

Force that is needed for this torque:

$$F = M \div r = 1325 \text{ Nm} \div 0,32 \text{ m} = 4140,6 \text{ N}$$

Acceleration is:

$$a = F \div m = 4140,6 \text{ N} \div 1500 \text{ kg} = 2,76 \text{ m/s}^2$$

Acceleration time from 0 to 100 km/h (=27, 77 m/s):

$$t = v \div a = 27,77 \text{ m/s} \div 2,76 \text{ m/s}^2 = 10 \text{ s}$$

Final EV speed:

Nominal DC battery voltage:	384 Vdc
Specific load motor speed:	7,5 RPM/1Vdc at full load

Maximal motor RPM according to specific load motor speed:

$$N_{mot} = 384 \text{ Vdc} * 7,5 \text{ RPM/1Vdc} = 2880 \text{ RPM}$$

Maximal wheel rotating at full load:

$$N_w = 2880 \text{ RPM} \div 2,65 = 1087 \text{ RPM}$$

Circumference of the wheel:

$$C_r = 2 * 3,14 * 0,32 \text{ m} = 2,01 \text{ m}$$

Maximal EV speed without magnetic field weakening:

$$V_{max} = 1087 \text{ RPM} * 60 * 2,01 \text{ m} \div 1000 = 131,1 \text{ km/h}$$

Note: Maximal EV speed can be much higher at the same power with magnetic field weakening (MFW). This setting can be made in the controller software.

Travel range with 30 kWh of battery capacity:

Average power, which is needed to drive EV approximately 100 km/h, is approximately 12 kW motor power. Therefore theoretically expected travel range is close to 250 km with one charging of the batteries. In practice the producer of the batteries does not recommend 100% discharging of the batteries, therefore 200 km is what can be expected in reality.

22. EMRAX Certificates

EMRAX motors are in the process of obtaining certificates.

Till now EMRAX motor obtained EMC certificate (E26) – electromagnetic field testing. This means that the motor complies with essential protection requirements of 89/336/EEC. It is important for electric vehicles.

23. EMRAX disclaimer

EMRAX company does not take any responsibility for difficulties, which are the result of inappropriate configuration, electric system structure and settings that are not in accordance with the latest version of Manual for EMRAX motors. Every motor is tested before shipping at ambient conditions and parameters, which are described in Technical data tables. If EMRAX motors are not used in accordance with this manual it causes a forfeit of warranty claims. Products of EMRAX company have been developed for usage on electric vehicles, planes, boats, power plants. Company EMRAX assumes no liability in case a customer uses components for the purposes for which they have not been developed or tested, and especially not for the purpose of presenting a direct threat to human life or health. EMRAX company does not take any responsibility for damages caused by using the motors in testing purpose in circumstances which differ from standard usage of the motor. Any responsibility of the EMRAX company expires in one year after the delivery of the motor. For maintenance and usage standards see Manual for EMRAX motors. The EMRAX company does not take any responsibility on damages, injuries or other consequential losses caused by product failure of the user or any third person.

General Terms and Conditions of EMRAX company are available here: www.emrax.com

24. Service

In case of a fault or damage, contact company EMRAX:

EMRAX d.o.o.
Pod hribom 4
1235 Radomlje
Slovenia, Europe

Phone: +386 8 2053850
E-mail: info@emrax.com
Web site: www.emrax.com

We now wish you lots of fun and success with your high performance EMRAX engine.